

# CXS DRY PUMPS VACUUM DRYING

[edwardsvacuum.com](http://edwardsvacuum.com)

## VACUUM DRYING

Vacuum drying uses pressure reduction to remove moisture or solvents from a substance. Reducing the pressure lowers the boiling point of liquids, allowing the removal of vapours at reduced temperatures.

Drying is usually a time-consuming process, so optimised solutions provide considerable savings in time, energy and costs. Vacuum improves the drying rate significantly for very dense products and is highly effective in the recovery of toxic constituents, valuable solvents or fragrances. It is essential for producing the low temperatures required to prevent degradation and improve product quality and viability.

As experts in vacuum technology, Edwards has a full understanding of drying processes and the importance not only of pump sizing and selection for effective solids and liquid handling but also the challenges presented by corrosive, flammable, explosive and poisonous chemicals.

Edwards CXS pumps are ideally suited to vacuum drying processes in the fine chemicals, food and pharmaceutical industries. They also offer significant advantages in processes used in plastics, ceramics, dyes, paint and pigments. They are available as standalone units or as complete systems in combination with booster pumps and accessories such as flame arrestors, knockout pots, condensers and filters.



## CXS BENEFITS

- **No fuss**
  - » Easy to install and control, quiet running, minimum maintenance
  - » Just “fit and forget”
- **Simply reliable**
  - » Even in difficult and demanding environments, with excellent liquid and solids handling
- **Low cost of ownership**
  - » Low energy usage and utility costs
- **Robust**
  - » Pumps corrosive vapours without corroding
- **Environmentally friendly**
  - » No contamination of the process stream or cooling water
  - » No effluent generation
- **Safety assured**
  - » ATEX certified for use in hazardous environments
  - » Explosion-proof
  - » Safe pumping of flammable gases
- **Outstanding support**
  - » From a global company famed for its best-in-class technology and applications expertise

**PRESSURE CONTROL WITH A CXS AND PRESSURE TRANSMITTER (PT)**

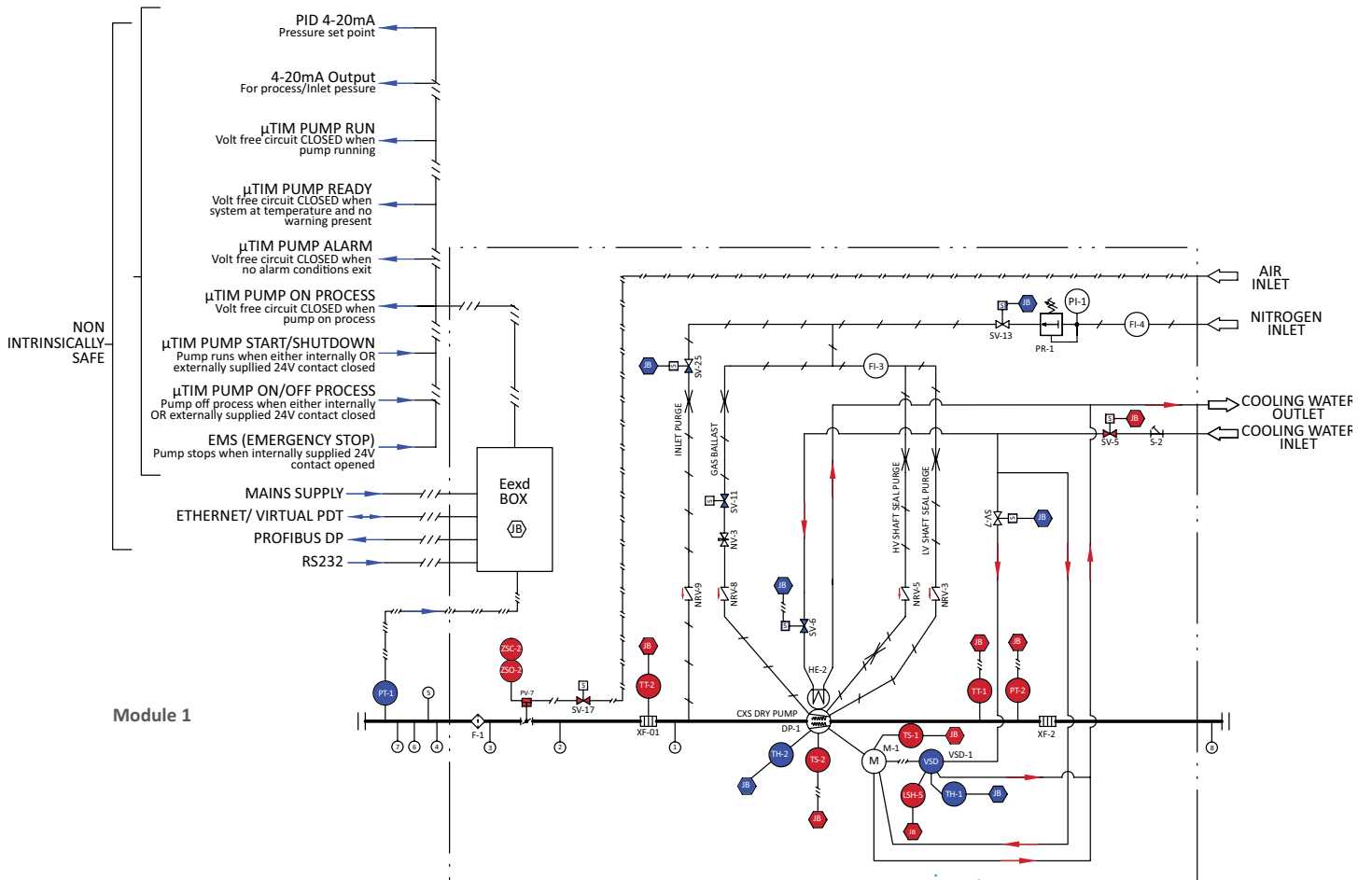
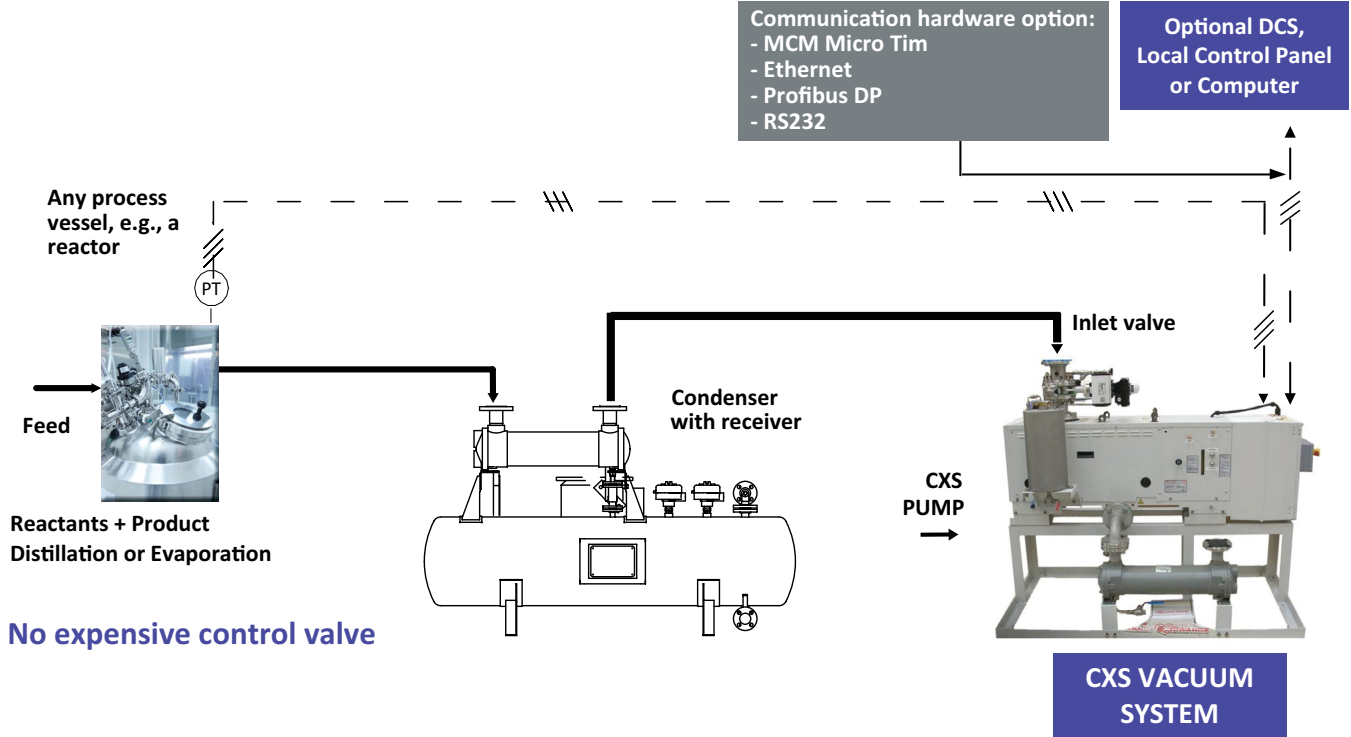

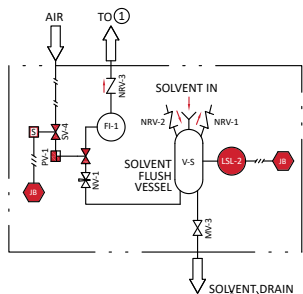

Module 2

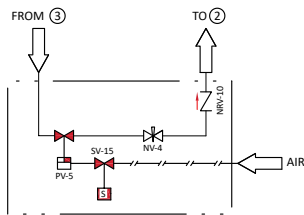

Module 3

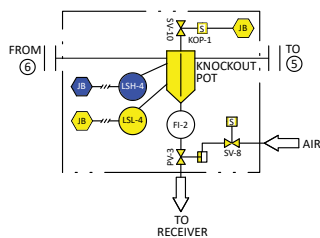

Module 4

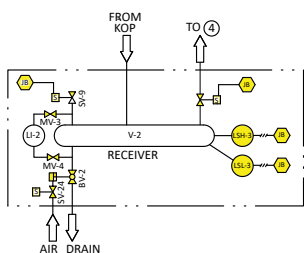

Module 5

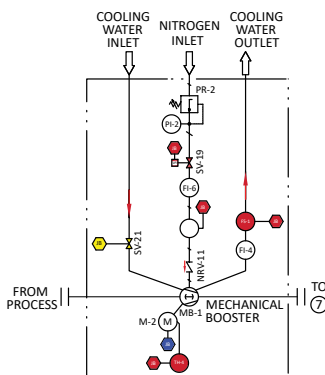

Module 6

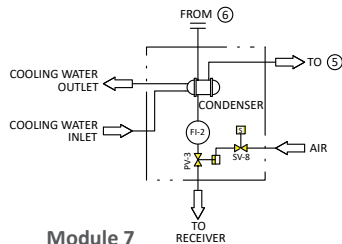

Module 7

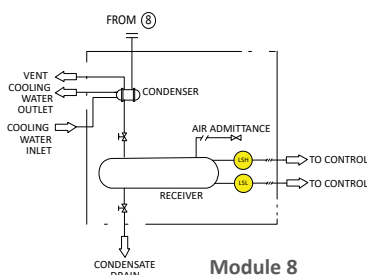

Module 8

- EXTERNAL CONTROLLER
- MAIN ONBOARD SAFETY CIRCUIT
- SAFETY CIRCUIT, EXTERNAL CONTROLLER
- PUMP CONTROLLER

LINE DESIGNATION :-	
PROCESS	—————
ELECTRIC SUPPLY/SIGNAL	—————
INSTRUMENT AIR	—————
NITROGEN SUPPLY	—————
WATER SUPPLY	—————
EDWARDS SCOPE OF SUPPLY	—————

**CXS MODULE OPTIONS:**

- Module 1:** CXS pump with purges, inlet and outlet flame arresters, inlet valve, inverter, controller & safety interlocks
- Module 2:** Solvent flush package
- Module 3:** Inlet valve by-pass line
- Module 4:** Inlet KOP with level control
- Module 5:** Inlet receiver with auto-drain
- Module 6:** EH mechanical booster
- Module 7:** Exhaust condenser & receiver
- Module 8:** Inlet condenser

**ADDITIONAL MODULE OPTIONS:**

- Exhaust silencer
- Dust filter
- Pressure control valve
- Other control options
- Local control panel
- Additional mechanical boosters
- Documentation packages
- System skid

**DRYING APPLICATIONS**

- Fine chemicals
- Speciality chemicals
- Pharmaceuticals and their intermediates
- Agrochemicals
- Plastics
- Paints, dyes and pigments
- Explosives

**WHEN TO USE CXS**

CXS pumps should be considered for vacuum drying when:

- Minimising drying times
- Low product temperatures are required to prevent degradation and improve product quality and viability
- Low final pressures are desirable
- An end product requires extremely low levels of residual liquids
- A heated product in contact with air causes oxidation or risk of explosion
- Recovery of toxic constituents, valuable solvents or fragrances is required
- Handling tricky materials, especially particulates, sticky substances and process upsets
- Good pressure controls are required during the drying cycle
- Fast recovery of equipment cost is required
- Clean, reliable, safe vacuum is required

## CXS FEATURES

- CXS chemical dry pumps feature cutting-edge tapered screw technology. Smooth, gradual compression along the length of the rotor results in improved thermal control and optimised performance at all inlet pressures
- An advanced temperature management system maintains the pump temperature at programmable levels for optimal, repeatable process performance
- The innovative design uses flooded air-gap potted, high efficiency motors. Integral drive and control systems further help to lower the cost of ownership
- Quiet running, with noise levels typically as low as 64 dB(A)
- CXS chemical dry pumps are designed to be good at handling solids and easy to restart. They can handle at least one litre of liquid per minute continuously and slugs of up to 25 litres without stopping
- An integral controller, PID pressure control and safety systems allow for 'plug and pump' operation. Pumps can be linked to any external control system via a variety of interfaces including Ethernet and Profibus DP
- CXS chemical dry pumps have a long service interval of up to five years and require minimal maintenance over their life expectancy of more than 25 years
- No routine service required

## SYSTEMISATION

Systemisation is an important consideration for successful vacuum pumping on drying applications. With CXS chemical dry pumps, systemisation is made easy. Using an extensive range of pre-engineered modules, the CXS range offers the capability to match most customer application needs.

CXS pumps are available as stand-alone pumps or as part of a complete system, including mechanical boosters for higher pumping capacities. They can also be enhanced with a range of other standard accessories such as valves, flame arresters, solvent flush kits, condensers, knockout pots and dust filters.

Two models are available, the CXS160 and CXS250, which give nominal capacities of 160 m<sup>3</sup>h<sup>-1</sup> and 250 m<sup>3</sup>h<sup>-1</sup> respectively.



## GLOBAL CONTACTS

Publication Number: 3602 573 1 01  
© Edwards Limited 2021. All rights reserved  
Edwards and the Edwards logo are trademarks of Edwards Limited

Whilst we make every effort to ensure that we accurately describe our products and services, we give no guarantee as to the accuracy or completeness of any information provided in this datasheet.

Edwards Ltd, registered in England and Wales  
No. 6124750, registered office: Innovation Drive,  
Burgess Hill, West Sussex, RH15 9TW, UK.

<b>EMEA</b>	
<b>UK</b>	+44 1444 253 000 (local rate) 08459 212223
<b>Belgium</b>	+44 (0) 1293 60 3350
<b>France</b>	+33 1 4121 1256
<b>Germany</b>	0800 000 1456
<b>Italy</b>	+ 39 02 48 4471
<b>Israel</b>	+ 972 8 681 0633
<b>Russia</b>	+ 749 5 933 5550 Ext. 1800/1803 + 880 0 775 8099

<b>ASIA PACIFIC</b>	
<b>China</b>	+86 400 111 9618
<b>India</b>	+91 20 4075 2222
<b>Japan</b>	+81 47 458 8836
<b>Korea</b>	+82 31 716 7070
<b>Singapore</b>	+65 6546 8408
<b>Taiwan</b>	+886 3758 1000

<b>AMERICAS</b>	
<b>USA</b>	+1 800 848 9800
<b>Brazil</b>	+55 11 3952 5000