

nXLi AIR COOLED SINGLE PHASE DRY PUMP

edwardsvacuum.com



Edwards is delighted to introduce the new air cooled nXLi dry pump range, designed to deliver a consistent performance worldwide with complete user flexibility in mind. This new single phase pump is available in two options: nXL110i and nXL200i. Both are optimised for LCMS and ICPMS duties and are capable of handling gas loads of up to 25 slm. nXLi can also be used on chambers up to 100 litres, at continuous inlet pressures up to 15 mbar with occasional pump down.

TWO PUMPING SPEEDS
110 m³h⁻¹ AND 200 m³h⁻¹

INTELLIGENT DRIVE
TRANSIENT OVERLOAD
PROTECTION

FLEXIBILITY OF
CONTROL

AIR COOLED SINGLE
PHASE POWER INPUT
200 TO 240 V 50/60 Hz



Worldwide consistent performance, you've got it!

Performance is at the core of nXLi. The intelligent drive enables the system to achieve an enhanced performance plateau from single phase power supply, and a consistent worldwide operation from a 200 - 240 V (+/-10%) 50/60 Hz single phase supply. The choice of control options are either manual, simple remote or serial communications (RS485 with modbus command set). These may be utilised to provide real control for the system builder.

Innovate your world with nXLi

nXLi provides a small footprint with quiet operation making it a convenient and flexible high performing, yet compact, vacuum pump. The oil-free non-contacting pump mechanism will provide extended operation with maximum up time, up to five years service life, with zero maintenance and no oil to dispose of.

During the initial chamber pump down the nXLi is able to work harder than normal. The intelligent transient overload protection will allow a higher power draw for a short period of time for initial evacuation of the chamber from atmospheric pressure to operating pressure. This higher initial power boost enables the pump to overcome initial gas loads and once operating pressure is achieved less power is required.

nXLi is the latest addition to the Edwards intelligent pumping range and is the ideal dry pump for Scientific OEMs, LCMS end users, ICPMS end users and in applications where a consistent performance, control and reliability are essential.



ORDER INFORMATION

Product description	Order number
nXL110i NW40 200-240V 50/60 Hz	A77012320
nXL110i NW50 200-240V 50/60 Hz	A77012420
nXL200i NW40 200-240V 50/60 Hz	A77022320
nXL200i NW50 200-240V 50/60 Hz	A77022420

ACCESSORIES AND SPARES

Product description	Order number
2m electrical supply cable, UK, three pin plug	A50505003
2m electrical supply cable, North European Plug	A50506003
2m electrical supply cable, North America/Japan plug	contact Edwards
2m electrical supply cable, right angled connector, UK, three pin plug	A50505006
2m electrical supply cable, right angled connector, North European plug	A50506006
2m electrical supply cable, right angled connector, North America/Japan plug	contact Edwards
Digital operator	D37520056

Time to make the intelligent choice

Air cooled single phase dry pump

Offering two pumping speed options of either 110 m³h⁻¹ or 200 m³h⁻¹ in the pressure range of 1 to 10 mbar

Intelligent drive transient overload protection

Enables the system to achieve the enhanced performance plateau from single phase power supply, whilst looking after the pump during initial pump down

Flexibility of control

Manual control, simple remote control and serial communications (RS485 with Modbus command set) with a proven track record of performance control as standard allow more control options for the system builder

Compact and quiet

Small footprint and quiet operation for an improved work environment and better use of lab space

Oil free non contacting pump mechanism

No oil to dispose of and maintenance free ensures extended operation and maximum up time

Built-in exhaust valve for anti-suck-back protection

Proven reliability

Based on Edwards iXL range of semiconductor dry pump technology for peace of mind with a proven track record of performance

TECHNICAL DATA

	Units	nXL110i	nXL200i
Pumping speed (pneuop 6602)	m ³ h ⁻¹	110	200
Ultimate vacuum (total pressure)	mbar	<2 x 10 ⁻²	
Inlet flange		NW40	
Outlet flange		NW40 / NW50	
Maximum permitted outlet pressure	bar gauge/psig	0.5 / 7.0	
Operating temperature range	°C	10 - 40	
Nominal rotational speed	rpm	9000	
Power connector 1-ph		IEC EN60320 C19	
Mains voltage	V	200-240 (+/- 10%)	
Power at typical application condition (2-10 mbar)	kW	0.7 - 0.9	
Flow at typical application condition	slm	3-15	6-22
Leak tightness	mbar ls ⁻¹	1.0 x 10 ⁻⁵	
Weight	kg	75	81
Noise (pressure)	dB(A)	56.7	
Vibration at inlet flange	mms ⁻¹ (rms)	<2.5	

*Alternative connections available upon request

DIMENSIONS – MM

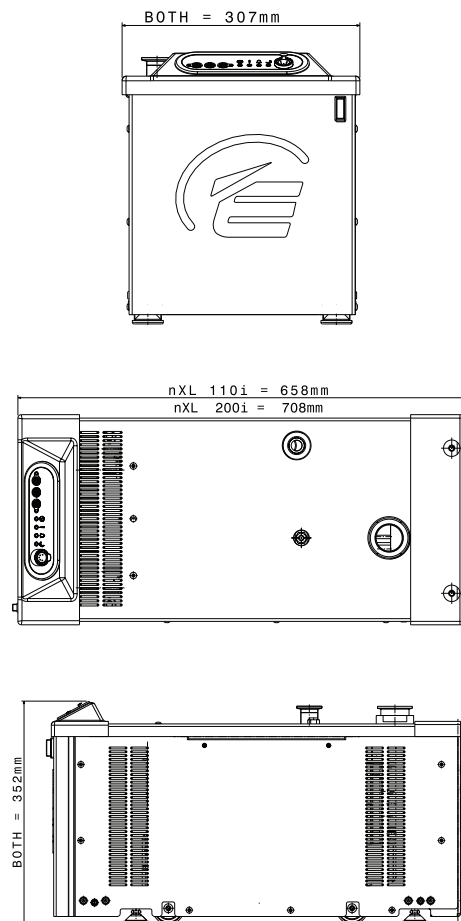

PERFORMANCE GRAPH

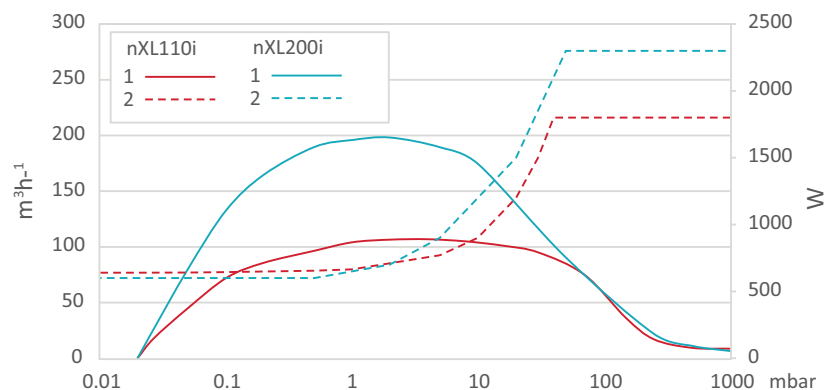

	nXL110i	nXL200i
Pumping Speed	— (red solid)	— (blue solid)
Power	- - - (red dashed)	- - - (blue dashed)

Publication Number: 3601 0330 01
 © Edwards Limited 2020. All rights reserved. Edwards and the Edwards logo are trademarks of Edwards Limited

Whilst we make every effort to ensure that we accurately describe our products and services, we give no guarantee as to the accuracy or completeness of any information provided in this datasheet.

Edwards Ltd, registered in England and Wales
 No. 6124750, registered office: Innovation Drive, Burgess Hill, West Sussex, RH15 9TW, UK.

