

ELD500 PRECISION LEAK DETECTOR TROLLEY

edwardsvacuum.com

Our new trolley is designed to fit various combinations of an ELD500 leak detector with primary vacuum pumps and accessories. The ELD500 can be easily mounted to the boreholes, using the feet-screws of the ELD500 to fix the leak detector to the upper plate of the trolley. An additional drawer gives storage space for small accessories and/or documents. The trolley offers flexible mounting possibilities for primary vacuum pumps with Z-Profiles in the bottom to be fixed to the pump feet. The pump with the Z-Profiles mounted can then be fixed to the trolley. The trolley offers space to mount pumps of sizes up to height=450mm x length=623mm x width=320mm – additional space for the vacuum connections and electric ports needs to be considered. A variable helium bottle holder allows mounting and fixing helium bottles of up to 205mm diameter.



FEATURES AND BENEFITS

- Compact
- Minimal footprint
- Fully assembled
- No systemisation required
- Robust construction
- Low cost of ownership

DIMENSIONS

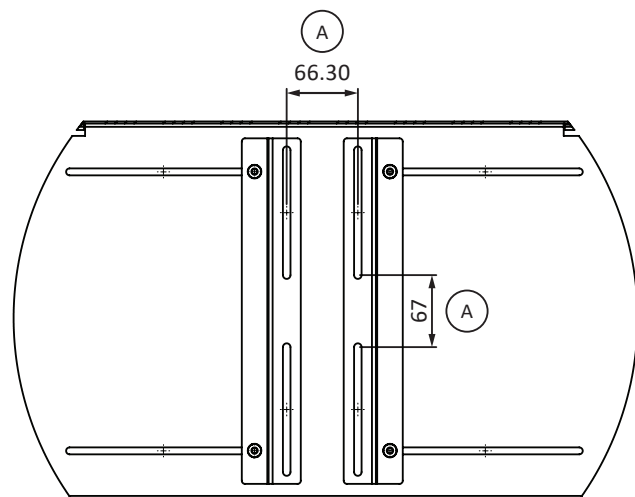
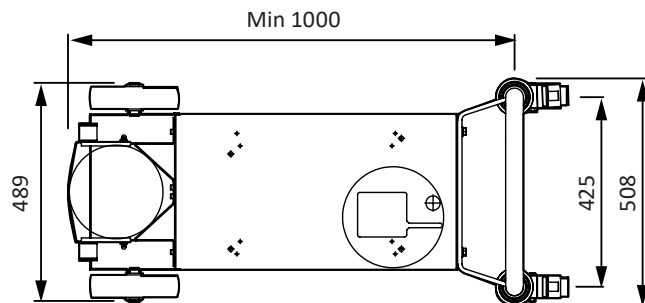
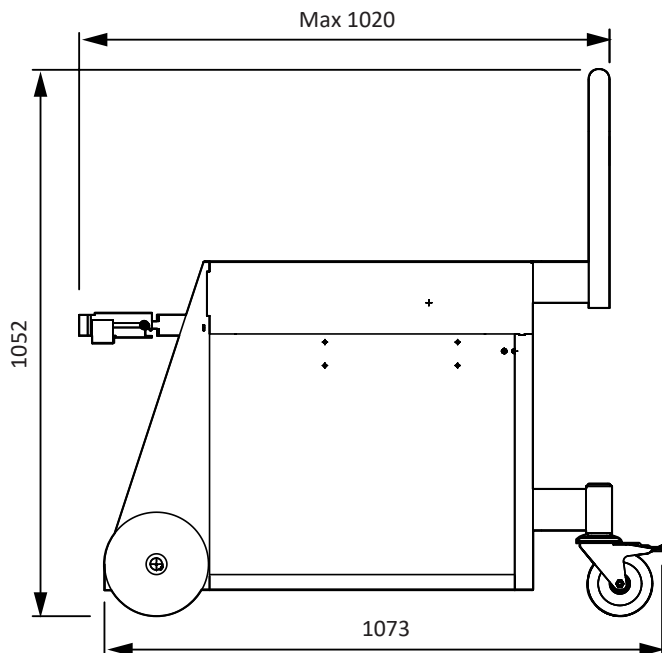

A Min Clamping Area

ORDERING INFORMATION

| Product description | Order number |
|--------------------------------------|--------------|
| ELD500 Trolley | D13550630 |
| Delivery scope | |
| Cart, Z-Profiles incl. 4 screws/nuts | |

Publication Number: 3601 0509 01
 © Edwards Limited 2019. All rights reserved Edwards and the Edwards logo are trademarks of Edwards Limited.

Whilst we make every effort to ensure that we accurately describe our products and services, we give no guarantee as to the accuracy or completeness of any information provided in this datasheet.

Edwards Ltd, registered in England and Wales
 No. 6124750, registered office: Innovation Drive, Burgess Hill, West Sussex, RH15 9TW, UK.

