

CALIBRATION SYSTEM ECAL1

edwardsvacuum.com

Calibration System ECAL1 is a fully automatic pumping system based on the Edwards T-Station 85H. A vacuum chamber equipped with two reference gauges is attached.

The calibration system provides output comparison between reference gauges and test gauges for a pressure range from 1000 to 10^{-4} mbar. The user must define the acceptable tolerance between reference gauges and the test gauges whilst taking into consideration the uncertainty of different calibration conditions. Note that no adjustment is performed on the test gauges during the calibration procedure.

The reference pressure gauges are connected and controlled via a TIC instrument controller. The TIC instrument controller is equipped with an intuitive easy-to-use graphical interface via a touch sensitive panel. The result can be observed on the TIC controller or connected via RS232/485 for control and data monitoring on a remote PC.

Reference gauges come with a factory calibration certificate. It is recommended that reference gauges are re-calibrated annually. Contact Edwards for details on this service.

**Reference pressure gauges are Barocel 7025 capacitance gauges from the Edwards Barocel 7000 series.*



FEATURES AND BENEFITS



EASY TO USE



TABLE TOP
CONFIGURATION



QUICK ASSURANCE OF
ACCURACY OF TEST GAUGES



TIC INSTRUMENT CONTROLLER

- Automatically recognizes and controls active gauges.
- Six user configurable relay set-points.
- Display of relay status.



PLUG-AND-PUMP

- Simple user-friendly plug-and-pump solution with no systemisation and no additional air cooling required, supplied fully assembled and ready to go for quick and easy operation.

APPLICATION AND MARKETS

A wide range of Applications where accuracy and repeatability of vacuum is an important aspect of the quality process to safeguard the process stability and product quality.

TECHNICAL DATA

	Units	Standard calibration system
Calibration pressure range	mbar	between 1000 to 10 ⁻⁴ *
Ultimate vacuum	mbar	< 5 x 10 ⁻⁸ **
Ports for calibration vacuum chamber		3x NW16 for calibration gauges / 1x NW16 for gas admit
Type of protection (to IEC34-5: 1981)	IP	20
Ambient operating temperature range	°C	5 to 40
Ambient storage temperature range	°/°C	-30 to 70
Maximum ambient operating humidity	°C	max. 90% RH non-condensing at 40
Maximum operating altitude	m	max. 2000
Dimensions	mm	527(W) x 690 (H) x 375 (D)
Mass	kg	40
Mains connection	m	EU Schuko VDE / 10A (2m) / UK BS1363/ 13A (2 m) / JAPAN Plug NEMA 5-15P / 15A (2m) / US plug NEMA 5-15P / 15A (2m)

* depending on the number and measuring range of the reference pressure gauges

** for clean, dry and empty chamber

ORDERING INFORMATION

Product description	Order number
Standard Calibration System - 200-230V (EU, UK, JAPAN)	NZA631000
Standard Calibration System - 100-120V (US)	NZA638000

DIMENSIONS

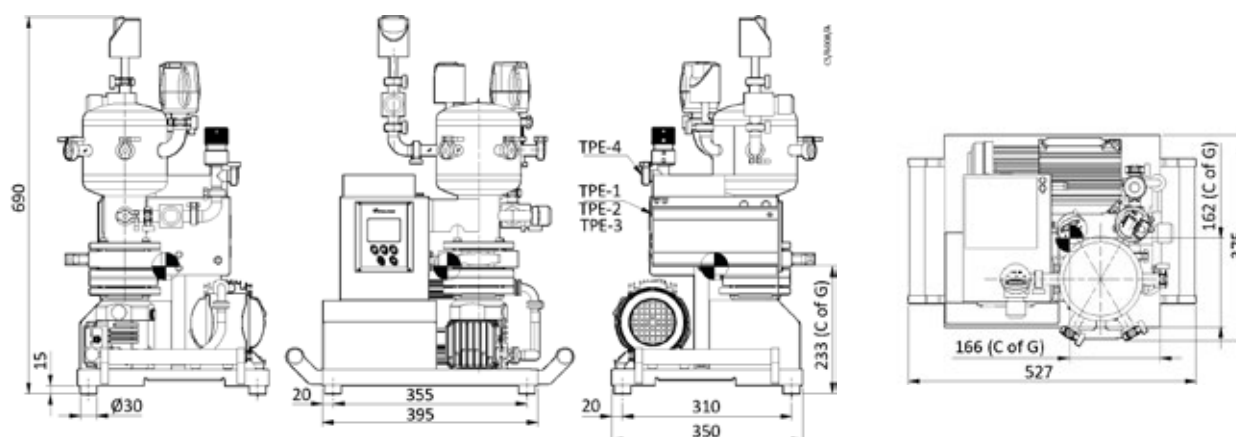

Publication Number: 3601 0732 01

© Edwards Limited 2022. All rights reserved Edwards and the Edwards logo are trademarks of Edwards Limited

Whilst we make every effort to ensure that we accurately describe our products and services, we give no guarantee as to the accuracy or completeness of any information provided in this datasheet.

Edwards Ltd, registered in England and Wales
No. 6124750, registered office: Innovation Drive, Burgess Hill, West Sussex, RH15 9TW, UK.

