

EDP CHEMICAL DRY VACUUM PUMP

edwardsvacuum.com

Edwards, a world leader in dry vacuum pump technology, successfully pioneered the use of environmentally friendly dry vacuum pumps in the early 1980s. With hundreds of thousands of systems installed worldwide, Edwards dry pumps create significant benefits for customers in many applications and industries.

This expertise is incorporated in our chemical dry pumps to satisfy the demanding requirements of the chemical, petrochemical and pharmaceutical industries. We offer a range of four pumps with 80 - 400 m³h⁻¹ capacity, and ultimate vacuums of less than 1 mbar. Our chemical dry pumps meet the highest safety and performance standards.

EDP pumps are based on Edwards' oil-free, non-contacting, award-winning, reverse claw mechanism. They provide consistent vacuum at high efficiencies and low costs of ownership. Dry pumps completely eliminate all problems of process contamination and the creation of polluted effluent, which are experienced with traditional wet vacuum pump technologies.



Features and benefits

- 1 Industry proven, tried and tested
 - Specifically designed for chemical applications
- 2 Designed and tested for safety and reliability
 - Stable operation, even during process upsets
- 3 Low cost of ownership
 - Easy maintenance, low utilities consumption and no cooling gas injection required

PRODUCT DATA SHEET

Specifications

	Units	EDP80		EDP160		EDP250		EDP400	
		50 Hz	60 Hz	50 Hz	60 Hz	50 Hz	60 Hz	50 Hz	60 Hz
Maximum pumping speed	m ³ h ⁻¹	83	102	163	202	260	320	377	427
	ft ³ min ⁻¹	49	60	96	119	153	188	222	251
Capacity at 10 mbar (7.5 Torr)	m ³ h ⁻¹	75	102	153	198	255	315	377	422
	ft ³ min ⁻¹	44	60	90	117	150	185	222	248
Ultimate vacuum	mbar	0.5	0.3	0.5	0.3	0.5	0.2	0.4	0.2
	Torr	0.4	0.2	0.4	0.2	0.4	0.2	0.3	0.2
Maximum back pressure - standard (optional*)	mbar	1150 (1300*)		1150 (1300*)		1150 (1300*)		1150	
	psig	2.2 (4.4*)		2.2 (4.4*)		2.2 (4.4*)		2.2	
Power consumption at 10 mbar (7.5 Torr)	kW	3.3	4.0	4.9	4.9	6.0	6.0	7.0	7.0
	hp	4.4	5.4	6.6	6.6	8.0	8.0	9.4	9.4
Standard motor (380 - 400V, 3 ph, 50 Hz)	kW	5.5	5.5	7.5	11.0	11.0	15.0	18.5	25.0
Standard motor (200 - 460V, 3 ph, 60 Hz)	hp	7.5	7.5	10.0	15.0	15.0	20.0	25.0	30.0
Cooling water flow rate (adjustable)	l min ⁻¹	1 - 8	1 - 10	1 - 8	1 - 10	1 - 10	1 - 10	1 - 10	1 - 10
	gal min ⁻¹	0.3 - 2.1	0.3 - 2.6	0.3 - 2.1	0.3 - 2.6	0.3 - 2.6	0.3 - 2.7	0.3 - 2.6	0.3 - 2.7
Cooling water supply pressure	barg	2 - 10							
	psig	29 - 145							
Seal purge flow (maximum), regulated to 0.3 - 0.5 barg (5 - 7 psig)	l min ⁻¹	20							
	ft ³ min ⁻¹	0.7							
Seal purge supply pressure (minimum - maximum)	barg	2 - 10							
	psig	29 - 145							
Noise (max. with exhaust silencer)	dB(A)	73	73	77	78	79	79	82	82
	kg	648	650	747	756	848	860	918	960
Weight (with frame and standard motor)	lbs	1429	1433	1647	1667	1870	1909	2024	2116
	ANSI/DIN	2"/DN50		3"/DN80		3"/DN80		3"/DN80	
Process connection, inlet	ANSI/DIN	1.5"/DN40		1.5"/DN40		2"/DN50		2"/DN50	
Process connection, outlet	ANSI/DIN	3 stage reversed claw							
Pumping mechanism									

* Consult Edwards

Data shown here refers to dry pumps only. Higher capacities and deeper vacuum levels are available by combining one or more dry mechanical boosters with EDP pumps. A wide range of systemisation accessories is also available, including condensers for enhanced performance and a number of safety, instrumentation and control options.

Although every care has been taken in the preparation of data and dimensional drawings, please discuss your individual requirements with Edwards.

PRODUCT DATA SHEET

Dimensions - mm (inch)

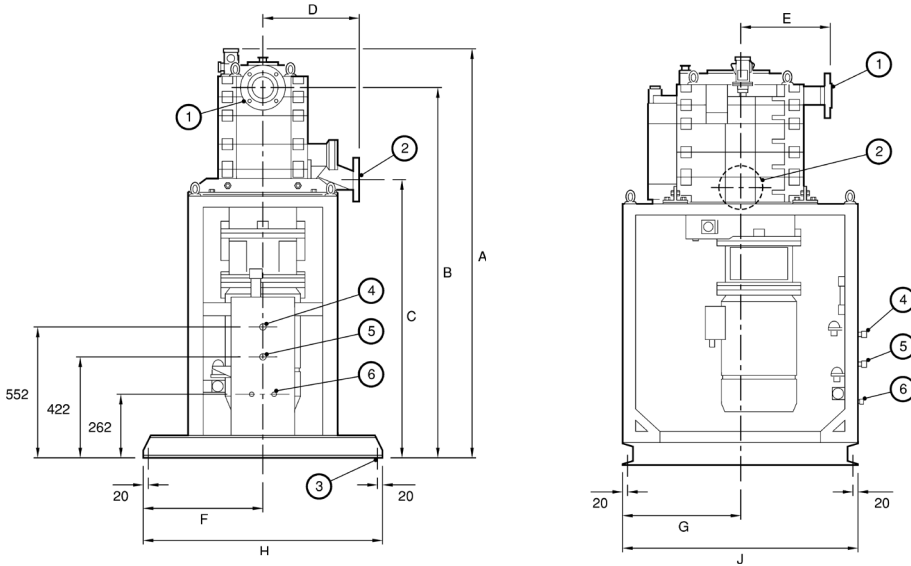

1. Pump inlet
2. Pump outlet
3. Fixing hole: Ø18 mm (4 off)
4. Cooling water outlet connection
5. Cooling water inlet connection
6. Nitrogen supply inlet connection

Key	EDP80	EDP160	EDP250	EDP400 50 Hz	EDP400 60 Hz
A	1423 (56.0)	1458 (57.4)	1681 (66.2)	1730 (68.1)	1721 (67.8)
B	1254 (49.4)	1289 (50.7)	1514 (59.6)	1562 (61.5)	1549 (61.0)
C	974 (38.3)	974 (38.3)	1148 (45.2)	1148 (45.2)	1149 (45.2)
D	353 (13.9)	353 (13.9)	377 (14.8)	377 (14.8)	349 (13.7)
E	443 (17.4)	448 (17.6)	359 (14.1)	359 (14.1)	362 (14.3)
F	350 (13.8)	350 (13.8)	500 (19.7)	500 (19.7)	476 (18.7)
G	350 (13.8)	350 (13.8)	475 (18.7)	475 (18.7)	476 (18.7)
H	700 (27.6)	700 (27.6)	1000 (39.4)	1000 (39.4)	997 (39.3)
J	850 (33.5)	850 (33.5)	950 (37.4)	950 (37.4)	946 (37.2)

Performance

Performance curve - 50 Hz

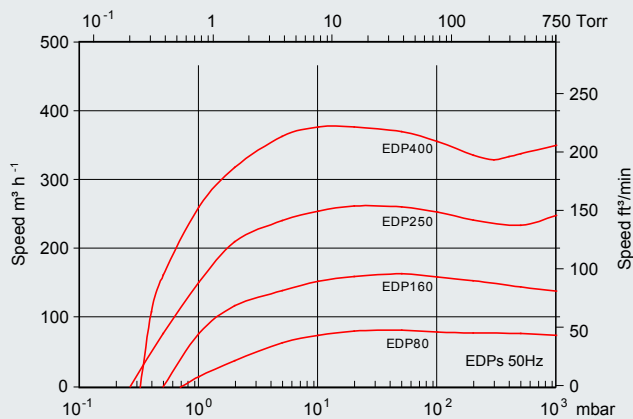

Performance curve - 60 Hz

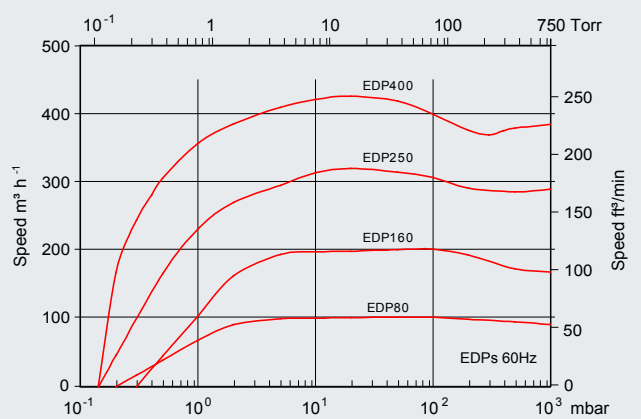

Standard Systems Dimensions - mm (inch)

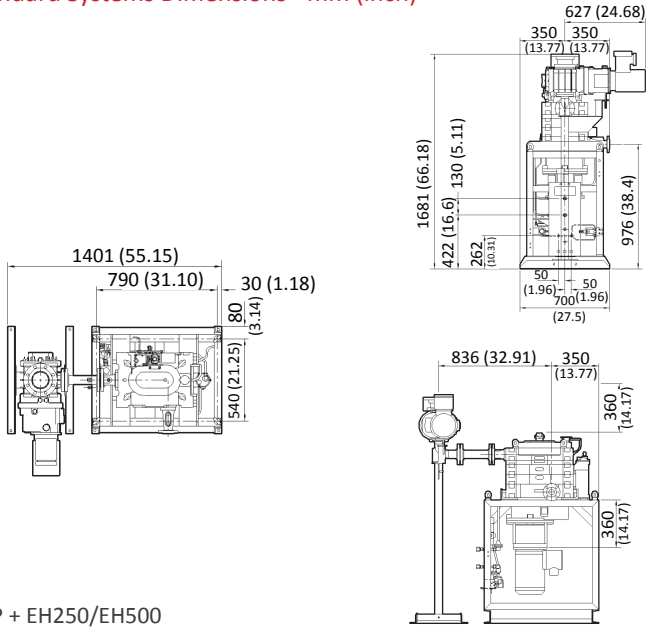

EDP + EH250/EH500

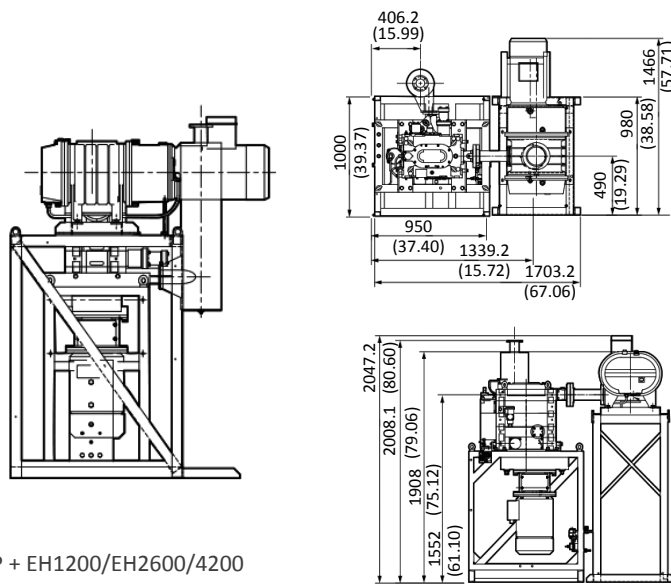

EDP + EH1200/EH2600/4200

Other combinations available.
Height and width dimensions will differ if using larger or smaller boosters.

Systemisation

- Custom systemisation design and build service
- Pre-engineered modules
- Tailored applications support to match performance to process

For performance with booster combinations, please refer to data below:

Performance curves

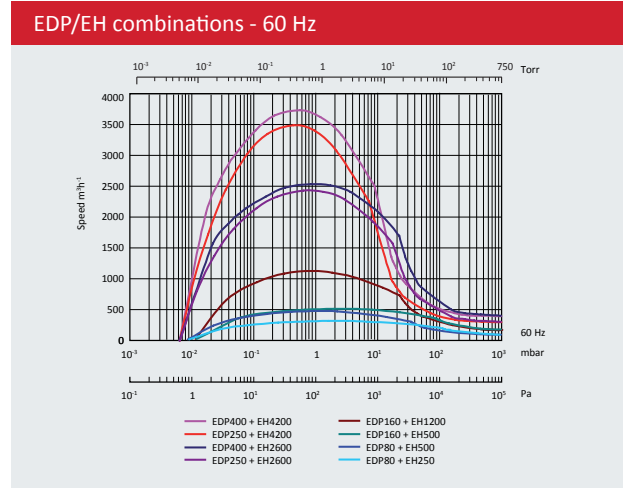
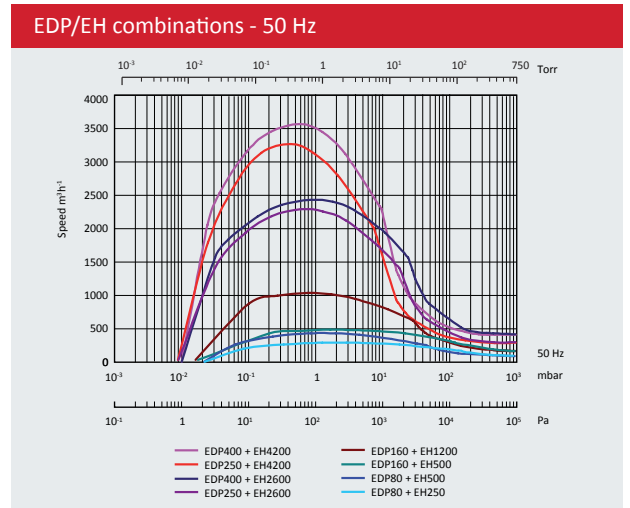

GLOBAL CONTACTS

Publication Number: 3602 104 6 01
© Edwards Limited 2016. All rights reserved Edwards and the Edwards logo are trademarks of Edwards Limited

Whilst we make every effort to ensure that we accurately describe our products and services, we give no guarantee as to the accuracy or completeness of any information provided in this datasheet.

Edwards Ltd, registered in England and Wales
No. 6124750, registered office: Innovation Drive,
Burgess Hill, West Sussex, RH15 9TW, UK.

EMEA

- UK** +44 1293 528844
(local rate) 08459 212223
- Belgium** +32 2 300 0730
- France** +33 1 4121 1256
- Germany** 0800 000 1456
- Italy** + 39 02 48 4471
- Israel** + 972 8 681 0633

ASIA PACIFIC

- China** +86 400 111 9618
- India** +91 20 4075 2222
- Japan** +81 47 458 8836
- Korea** +82 31 716 7070
- Singapore** +65 6546 8408
- Taiwan** +886 3758 1000

AMERICAS

- USA** +1 800 848 9800
- Brazil** +55 11 3952 5000

