

POLYCOLD® PFC FAST CYCLE WATER VAPOR CRYOCHILLER

edwardsvacuum.com

The Polycold Fast Cycle Water Vapor Cryochillers (PFC) effectively captures water vapor, which comprises 65% to 95% of the residual gas in high-vacuum systems. Water vapor is typically the most reactive contaminant present. With the PFC cryochillers, you can expect to increase product throughput in your existing system 20% to 100% and improve quality of deposition.

The PFC Advantage

- High-vacuum pumpdown time cut by 25% to 75%
- High-speed pumping of water vapor: up to 105,000 l/sec in the workspace
- Increased product throughput of 20% to 100%
- Typical payback times of less than one year
- Lower water vapor partial pressure during processing for higher film quality, better adhesion and more reproducible deposition
- Superior in cost/performance to liquid nitrogen cooled Meissners

When added to your vacuum system, the PFC Cryochiller can dramatically reduce pumpdown times and increase product throughput. The PFC will pump water vapor within minutes from “start” and can defrost in less than four minutes, giving true fast-cycle capability. For your system, this means more production cycles per shift. Pumpdown times are typically reduced by 25% to 75%, and increases in product throughput are 20% to 100%.

Using Polycold’s patented cryogenic refrigeration process, and patented refrigerant mixtures, the PFC works on the principle of Meissner trapping. Water vapor is captured by condensation on a cryogenically cooled surface, called a Meissner coil. The Meissner (cryocoil) is mounted directly in the vacuum chamber so conductance is not limited by ports, manifolds, valves and baffles. The cryocoil is easy to install and can be adapted to fit any system. It does not need a high-vacuum valve.

PFC Cryochillers are the most cost-effective pumping upgrade you can add to any diffusion-pumped, turbopumped or helium-cryopumped system. A control module allows you to have either local or remote operation, enabling you to operate the PFC from your existing controller or processor.

The PFC is available in a variety of capabilities and cryocoil configurations. Models are available that control two cryocoils or the combination of a cryocoil and a baffle.



Features and Benefits

- -115° to -140°C (158° to 133° K)
- Heat Removal to 1500 Watts
- Cryocondenses Water Vapor in Vacuum Systems with Speeds to 105,000 l/sec Vacuum Levels to 1.5 x 10⁻⁹ torr (2 x 10⁻⁹ mbar)
- Provides very fast pumping speeds for water vapor, which is typically 65% to 95% of the gas load in high vacuum systems.
- Based on Polycold’s proven, innovative, dependable mixed-gas cryogenics
- ISO 9001:2015 certified manufacturer
- CE Marked to the PED

Features

All PFC Cryochiller models have the following features in common:

Self-Diagnostics: All PFC Cryochiller models include self-diagnostics to assist the user.

Compliance: PFC Cryochillers are compliant to EU PED, MD and RoHS. TUV Rheinland listed to NRTL/Canada safety standards.

24V Remote: The PFC has an option for a 24V remote, which allows for direct wiring of inputs to and outputs from the unit. The 24V remote is Non-Isolated and may be for a Single Circuit or Dual Circuit system.

Temperature meter: Included as standard in this module is a digital temperature meter with a ten-position thermocouple select switch for easy temperature monitoring.

Options

VCR fittings: Optional VCR fittings for cryocoil connection. Parker-compatible fittings are standard.

Dual Circuit: Enables the PFC to cool two cryosurfaces (two cryocoils, coil and baffle or two baffles) which can be cooled or defrosted separately.

24V Isolated Remote: The PFC can be configured with an Isolated remote for backwards compatibility. This may be used for a Single Circuit or Dual Circuit system.

Temperature Setpoint Relay: Indicates that the selected temperature is colder than the predetermined setpoint. Inside the module, the setpoint can be adjusted between -80C and -160C. When the temperature from the input thermocouple drops below the defined setpoint, a thermocouple limit switch lights a lamp on the panel and closes a relay contact which completes a circuit to the remote connector.

System Accessories

Cryocoil

The cryocoil can be designed to fit your specific vacuum chamber. Typical cryocoils have helical, spiral, serpentine or other simple shapes. We do not recommend cryopanel, due to slow cool/defrost times as a result of their increased mass and ineffective cryopumping on the rear side when positioned near the chamber wall.

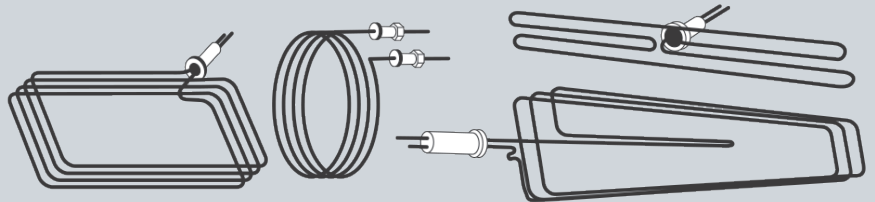

Feedthrough

The standard cryogenic feedthrough provides thermal isolation between the feed/return tubes and the O-ring seal. The dual-pass feedthrough requires a two inch diameter hole in the vacuum chamber. Couplings on the feedthrough mate with the refrigerant line. Optional feedthroughs fit one-inch diameter holes, but two are required (one for each tube).

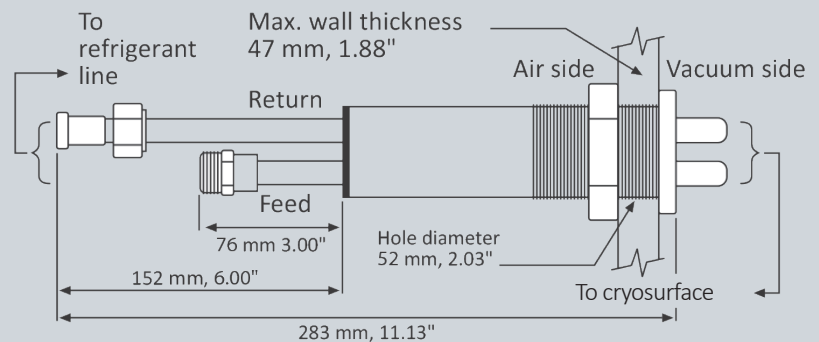

Refrigerant Line

A standard refrigerant line set consists of a copper feed and return line, each with stainless steel couplings on both ends for connection to the PFC unit and to the feedthrough. Longer lengths of refrigerant line (more than the standard 8 feet/2.44 m) can be ordered from the factory, but will require our applications review.

Direction of refrigerant flow

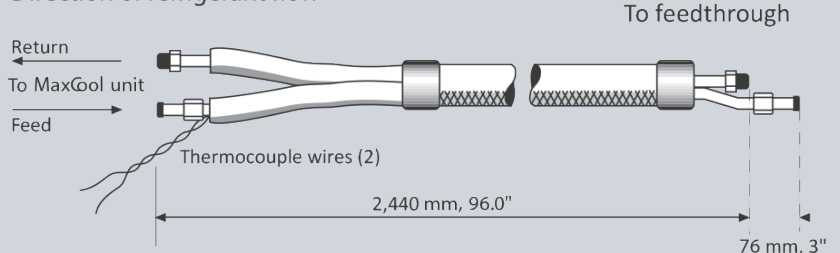

Frequently asked applications questions

How do I select the right model of PFC to trap water vapour in my vacuum chamber?

Determining the appropriate PFC system depends upon the desired water vapour pumping speed and the ability of the chamber to accommodate the required amount of cold element (cryocoil) surface area.

The larger the cryocoil, the greater the pumping speed. Typically, we recommend an increase in chamber net speed of four times the existing (net in-chamber) water vapour pumping speed. This typically results in a pumpdown time reduction from 25% to 75%.

Once the approximate unit size and cryocoil surface area have been established, the required temperature and cooling capacity of the system are reviewed against the presence of any additional heat load (long refrigerant lines, process heat, etc.).

Can I use the PFC Cryochiller for thermal management?

The PFC Cryochiller cools components in a wide variety of process steps in diverse markets such as semiconductor, flat panel display, data storage and space simulation.

Applications include refrigerant-cooled chucks or platens that regulate the temperature of substrates during manufacturing processes. The PFC Cryochiller can also cool an external heat exchanger for open-loop or closed-loop gas chilling processes.

What is the best temperature to trap water vapour effectively?

To find the cryosurface temperature that is best for your vacuum system, look for the ultimate base pressure of your system in the table below. This temperature provides 90% water vapour trapping efficiency.

Desired water vapour partial pressure		Average cryosurface temperature needed
torr	mbar	°C
1 x 10 ⁻³	1.3 x 10 ⁻³	-89.6
5 x 10 ⁻⁴	6.7 x 10 ⁻⁴	-93.4
2 x 10 ⁻⁴	2.7 x 10 ⁻⁴	-98.2
1 x 10 ⁻⁴	1.3 x 10 ⁻⁴	-101.6
5 x 10 ⁻⁵	6.7 x 10 ⁻⁵	-104.9
2 x 10 ⁻⁵	2.7 x 10 ⁻⁵	-109.1
1 x 10 ⁻⁵	1.3 x 10 ⁻⁵	-112.2
5 x 10 ⁻⁶	6.7 x 10 ⁻⁶	-115.1
2 x 10 ⁻⁶	2.7 x 10 ⁻⁶	-118.1
1 x 10 ⁻⁶	1.3 x 10 ⁻⁶	-121.5
5 x 10 ⁻⁷	6.7 x 10 ⁻⁷	-124.1
2 x 10 ⁻⁷	2.7 x 10 ⁻⁷	-127.5
1 x 10 ⁻⁷	1.3 x 10 ⁻⁷	-129.9
5 x 10 ⁻⁸	6.7 x 10 ⁻⁸	-132.2
2 x 10 ⁻⁸	2.7 x 10 ⁻⁸	-135.2
1 x 10 ⁻⁸	1.3 x 10 ⁻⁸	-137.3
5 x 10 ⁻⁹	6.7 x 10 ⁻⁹	-139.5
2 x 10 ⁻⁹	2.7 x 10 ⁻⁹	-142.1
1 x 10 ⁻⁹	1.3 x 10 ⁻⁹	-144.1

Helpful Information for Sizing Systems

- Radiation Heat Load on Cryocoil At 25°C
- At 25°C Ambient Conditions: 376.6 watts/m² (35 watts/ft²)
- Refrigerant Line Heat Load: 26.3 watts/m (8 watts/ft)
- Vacuum Jacketed Line Heat Load: 1.0 watts/m (0.3 watts/ft)
- Water Vapour Pumping Speed: 149,000 l/s/m² (13,842 l/s/ft²)
- Liquid Nitrogen Cooling: approximately 45 watts/litre/hour

PFC Performance

Water Vapor Pumping Speeds

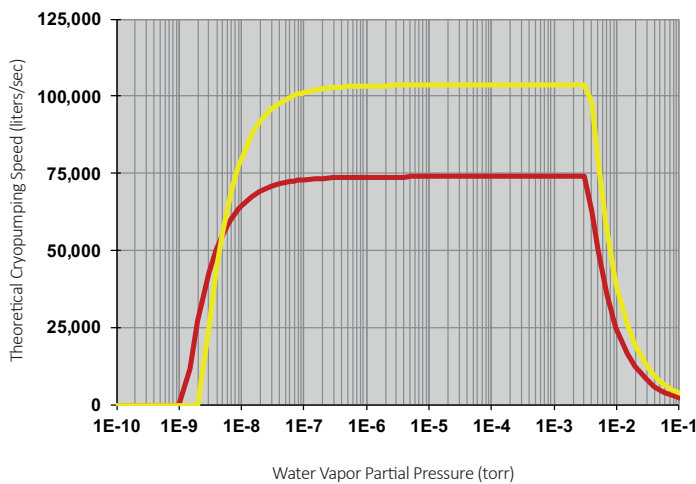

Single-circuit models; 25- 28°C cooling water; 2.4m refrigerant line; advertised cryocoil surface areas only; larger cryocoils will give greater pumping speeds and can be used in some applications; 25°C temperature in line of sight with cryocoil; 60Hz.

— PFC-552 HC
— PFC-672 HC

Cooling Capacities

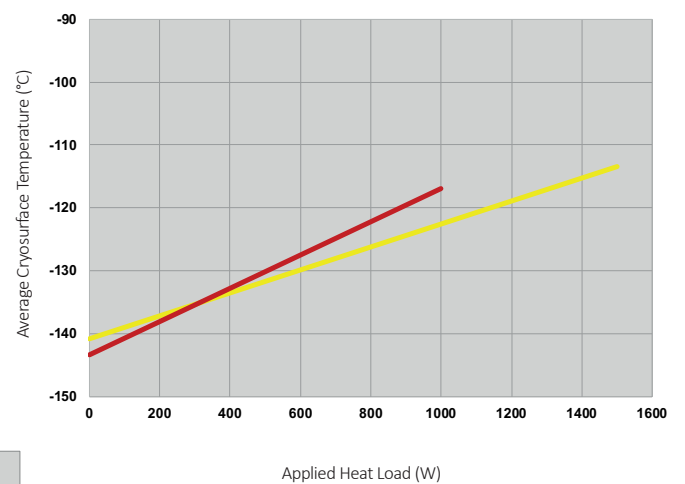

Single-circuit models; 25- 28°C cooling water; temperature shown is average of inlet and outlet temperature using typical cryocoil size; temperature difference between inlet and outlet at maximum load is typically 20°C; end point of each curve is maximum load for that model; performance at 50Hz can be 3- 5°C warmer than 60Hz performance shown.

PFC Specifications

Model	PFC 552HC	PFC 672HC
Typical Performance ^a		
Maximum Load (Watts at warmest temperature)	1000	1500
Theoretical max pumping speed l/sec ^b	74,500	105,000
Conservative pumping speed (in chamber) l/sec ^b	50,000	70,000
Ultimate Operating Pressure, torr ^c	2 x 10 ⁻⁹	6 x 10 ⁻⁹
Ultimate Operating Pressure, mbar	3 x 10 ⁻⁹	8 x 10 ⁻⁹
Maximum pump start pressure, atm ^d	1.0	1.0
Time to defrost, minutes	4.0	4.0
Cryocoils and Refrigerant Lines		
Total Cryocoil Surface area m ² (ft. ²)	0.5 (5.4)	0.7 (7.5)
Single Circuit (PFC)		
Tube O.D., mm (in.)	12 (1/2)	16 (5/8)
Tube Length m (ft.)	13.3 (41.1)	14 (46)
Dual Circuit (PFC/PFC)		
Tube O.D., mm (in.)	12 (1/2)	12 (1/2)
Tube Length per coil, m (ft.)	6.6 (20.6)	9.28 (29)
Standard refrigerant line lengths m (ft.)	2.44 (8)	2.44 (8)
Utilities		
Cooling water, flow rate l/min. (gal./min.)		
at 13C (55F)	4.9 (1.3)	6.8 (1.8)
at 26C (79F)	12.3 (3.2)	17.3 (4.6)
at 29C (85F)	19.7 (5.2)	27.6 (7.3)
Power Input, at maximum load, kW	6.0	8.3
Nominal Power Requirements ^e	200/3/50-60 230/3/60 380/3/50 400/3/50 460/3/60 480/3/60	200/3/50-60 230/3/60 380/3/50 400/3/50 460/3/60 480/3/60
Max Operating Sound Level, dB(A) ^f	71	72
Minimum Room Volume m ³ (ft. ³) ^g	13 (460)	16 (570)

Footnotes: (a) Standard conditions for performance testing. (1) Cryocoil environment at 20°C (2) Recommend cryocoils and line lengths (3) Cooling water temperature between 25°C and 28°C. (4) Operation at 60 Hz. (b) Larger cryocoils may give greater pumping speeds, and can be used in some applications. Contact your sales representative or the factory for application details. (c) Standard cryocoil at twenty five percent (25%) of maximum pumping speed. (d) Recommended cryopump start pressure is near normal "crossover." Mechanical roughing pumps and blowers are generally more effective for moisture removal above 1torr. (e) For nominal power requirements not on the table, please contact the factory. Please refer to the manual for operational voltage ranges. For 480 volt operation the maximum voltage is 506. (f) Units were tested in a manufacturing environment while under maximum load in the COOL mode. (g) To comply with the Safety Code for Mechanical Refrigeration, ANSI/ASHRAE-15-1994, the following units should be located in a room no smaller than listed. (h) 7.0 minute maximum defrost is for a 2 m2 coil. Most applications use smaller coils and achieve shorter defrost times. A 1 m2 coil with standard refrigerant lines will defrost in less than 4 minutes.

Notes: All units have cryocoils that may be decoupled from the refrigerant lines and remote control capability with built-in remote connector. Maximum angle of inclination for shipping or handling all units is forty-five degrees (45°)

PFC Dimensions and Weight

Model	PFC 672	PFC 552
Dimensions		
mm(inches)		
A	953 (37.5)	953 (37.5)
B	660 (26)	660 (26)
C	1842 (72.5)	1842 (72.5)
D	812 (32)	812 (32)
E	140 (5.5)	140 (5.5)
F	254 (10)	254 (10)
G	203 (8)	203 (8)
H	432 (17)	432 (17)
I	114 (4.5)	114 (4.5)
J	1727 (68)	1727 (68)
Weight		
kg(lb)	476 (1050)	408 (900)
Standard refrigerant line		
m(ft)	2.44 (8)	2.44 (8)

"Combination" or "Multi-Purpose" PFC Models have the same dimensions as the "Standard PFC" Models in the equivalent size unit. For PFC 552 and PFC 672 allow 45 cm (18 inches) clearance for utilities, refrigerant line connection and controls on the right hand panel as seen viewing the front of the unit.

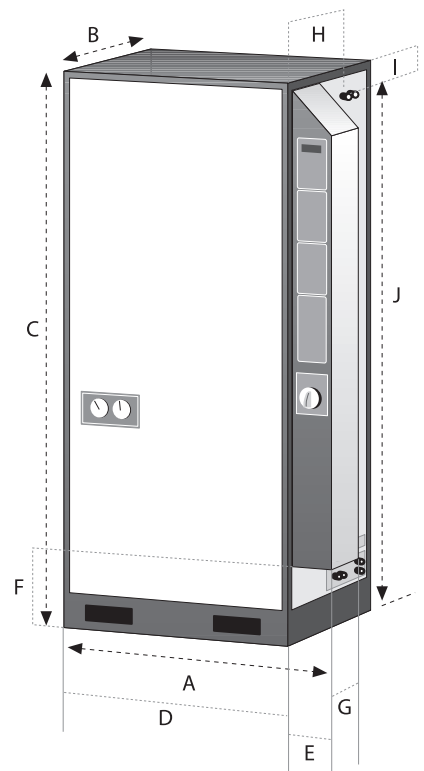

GLOBAL CONTACTS

© Edwards Limited 2021. All rights reserved Edwards and the Edwards logo are trademarks of Edwards Limited.

Whilst we make every effort to ensure that we accurately describe our products and services, we give no guarantee as to the accuracy or completeness of any information provided in this datasheet.

Edwards Ltd, registered in England and Wales
No. 6124750, registered office: Innovation Drive,
Burgess Hill, West Sussex, RH15 9TW, UK.

EMEA	
UK	+44 (0) 1444 253 000 (local rate) 0845 921 2223
Belgium	+32 2 300 0730
France	+33 1 4121 1256
Germany	0800 000 1456
Italy	+ 39 02 48 4471
Israel	+ 972 8 681 0633

ASIA PACIFIC	
China	+86 400 111 9618
India	+91 20 4075 2222
Japan	+81 47 458 8836
Korea	+82 31 716 7070
Singapore	+65 6546 8408
Taiwan	+886 3758 1000

AMERICAS	
USA	+1 800 848 9800
Brazil	+55 11 3952 5000

