

CXS chemical dry vacuum pump

CXS - An introduction

Chemical processes present special challenges when it comes to vacuum. Equipment often has to operate in damp, dusty, corrosive, flammable or explosive environments.

Whatever your process requirements, Edwards can provide an innovative and economic solution that is safe, flexible and reliable.

Building on long experience of vacuum applications, the new CXS range provides all the advantages of dry pumps while setting new standards for reliability, performance, control and economy.

CXS chemical dry pumps are ideally suited to even the harshest chemical and pharmaceutical processes and provide optimum performance in a wide range of applications, including distillation, drying, evaporation, reactor service, house vacuum, solvent recovery, sterilisation, fatty acid deodorisation and filtration.



CXS benefits

- Low cost of ownership
 - With low energy usage and utility costs
 - No routine service and major service intervals of up to five years
- Simply reliable
 - Even in harsh environments
 - Excellent liquid and solids handling
- Environmentally friendly,
 - No contamination of the process stream or cooling water,
 - No effluent generation
- Safety assured
 - ATEX certified for use in hazardous environments.
 - Pumps corrosive vapours without corroding
 - Explosion-proof to ensure safe pumping of flammable gases
- Flexible
 - Can be combined with booster pumps to provide deep and flexible vacuum down to 10^{-3} mbar
- Outstanding support from a global company
 - Famed for its best-in-class technology and applications expertise

Performance curves

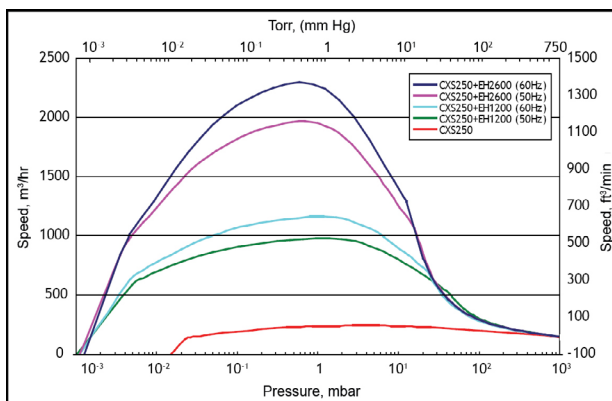
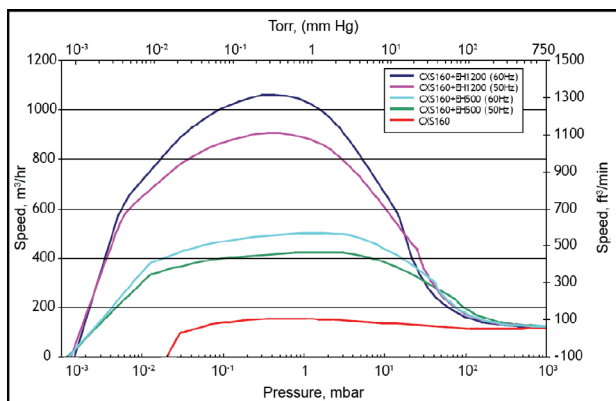

Key applications

	Chemical Dry Pump	Mechanical Booster	Rotary Piston Pump	Rotary Vane Pump	Liquid Ring Pump	Steam Ejector
Distillation, normal	✓✓	✓✓	✓	✓	✓✓	✓✓
Short path distillation	✓✓	✓✓	✓	✓		✓✓
Molecular distillation	✓✓	✓✓	✓	✓	✓	✓✓
Reactor service	✓✓	✓✓	✓		✓✓	✓
Central vacuum (flammables & corrosives)	✓✓	✓✓			✓✓	
Fatty acid deodorisation, Biofuels	✓✓	✓✓			✓✓	✓✓
Drying, evaporation, crystallisation, concentration	✓✓	✓✓	✓	✓	✓	✓
Gas recovery/recirculation	✓✓	✓✓				
Degassing	✓	✓	✓	✓✓	✓	✓
Absorption, Adsorption, Desorption	✓✓	✓✓			✓✓	
Pervaporation	✓✓	✓✓			✓✓	
Solvent recovery	✓✓	✓✓			✓	
Isocyanates production	✓✓	✓✓		✓	✓✓	✓✓
Impregnation	✓✓	✓✓	✓✓	✓✓	✓✓	
Polymers and plastics production	✓✓	✓✓	✓	✓	✓✓	✓✓
Paints, pigments, coatings and ink production	✓✓	✓✓	✓	✓✓	✓	✓
Soaps/detergents production	✓✓	✓✓	✓			✓✓
Ethylene Oxide sterilisation	✓✓	✓✓		✓✓		
Oil treatment plants	✓✓	✓✓	✓✓	✓	✓	✓
Dewatering and filtration	✓				✓✓	
Flammable and corrosive gases	✓✓	✓✓		✓	✓✓	✓✓
✓✓ - Preferred technology or widespread use ✓ - Some applications						
	Lowest cost of ownership, typically		High cost of ownership, typically		Highest cost of ownership, typically	

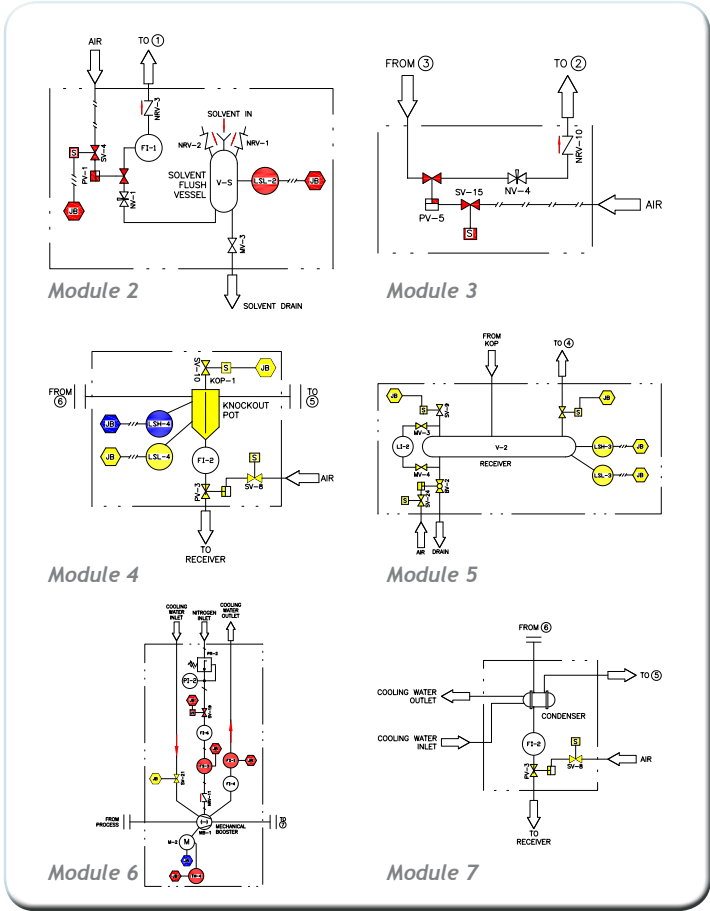
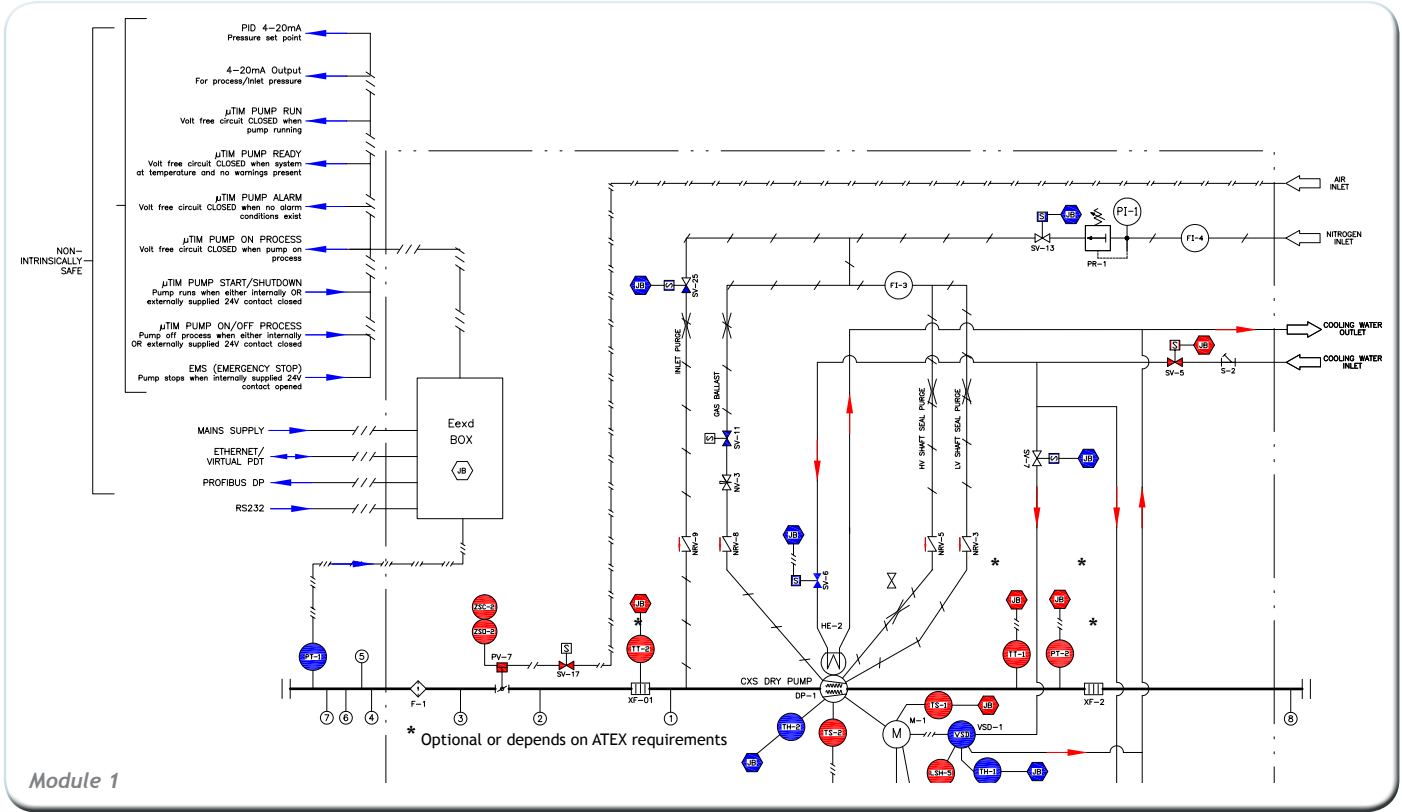

CXS Module options:

- Module 1: CXS Pump with Purges, Inlet and Outlet Flame Arresters, Inlet Valve, Inverter, Controller & Safety Interlocks
- Module 2: Solvent Flush Package
- Module 3: Inlet Valve By-pass Line
- Module 4: Inlet KOP with Level Control
- Module 5: Inlet Receiver with Auto-drain
- Module 6: EH Mechanical Booster
- Module 7: Exhaust Condenser & Receiver

Additional Module Options:

- Exhaust Silencer
- Dust filter
- Pressure Control Valve
- Other Control Options
- Additional Mechanical Boosters
- Documentation Packages
- System Skid

	EXTERNAL CONTROLLER
	MAIN ONBOARD SAFETY CIRCUIT
	SAFETY CIRCUIT, EXTERNAL CONTROLLER
	PUMP CONTROLLER

LINE DESIGNATIONS :-	
PROCESS	—————
ELECTRIC SUPPLY/SIGNAL	—————
INSTRUMENT AIR	—————
NITROGEN SUPPLY	—————
WATER SUPPLY	—————
EDWARDS SCOPE OF SUPPLY	—————

CXS features

- CXS chemical dry pumps feature cutting-edge tapered screw technology. Smooth, gradual compression along the length of the rotor results in improved thermal control and optimised performance at all inlet pressures.
- An advanced temperature management system maintains the pump temperature at programmable levels for optimal, repeatable process performance.
- The innovative design uses high efficiency air-gap potted motors.
- Integral drive and control systems further help to lower the cost of ownership.
- The pump mechanisms are smooth and quiet running, with noise levels as low as 64 dB(A).
- They can pump up to one litre of liquid per minute continuously and slugs of up to 25 litres without stopping. CXS chemical dry pumps are designed to be good at handling solids and easy to restart.
- An integral controller, PID pressure control and safety systems allow for 'plug and pump' operation. Pumps can be linked to any external control system via a variety of interfaces including Ethernet and Profibus DP.
- CXS chemical dry pumps have a long service interval of up to five years and require minimal maintenance over their life expectancy of more than 25 years.

Systemisation

CXS chemical dry pumps are available as stand-alone pumps or complete systems, including mechanical boosters for higher pumping capacities, and can be enhanced with a range of standard accessories such as valves, flame arresters, condensers, knock-out pots and filters.

Two models are available initially, the CXS160 and CXS250, which give nominal capacities of 160 m³h⁻¹ and 250 m³h⁻¹ respectively.

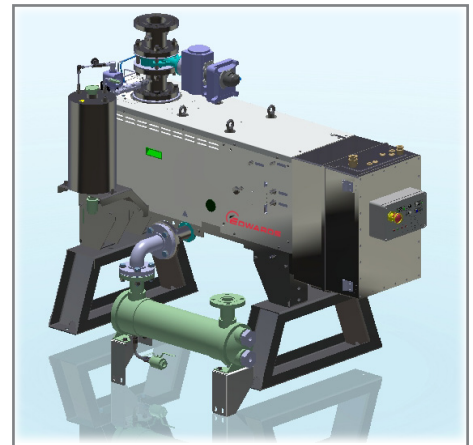

Global contacts

EUROPE

UK Crawley +44 1293 528844
UK (local rate) 08459 212223
Belgium Brussels +32 2 300 0730
France Paris +33 1 4121 1256
Germany Munich 0800 000 1456
Italy Milan +39 02 48 4471

USA

Niagara (toll free) +1 800 848 9800

BRAZIL

Sao Paulo +55 11 3952 5000

ISRAEL

Qiryat-Gat +972 8 681 0633

ASIA PACIFIC

China (toll free) +86 400 111 9618

India, Pune +91 20 4075 2222

Japan, Yachiyo +81 47 458 8831

Korea, Bundang +82 31 716 7070

Singapore +65 6546 8408

Taiwan R.O.C. Jhunan Town +886 3758 1000



WWW.EDWARDSVACUUM.COM

info@edwardsvacuum.com

Publication Number: P41100230, Issue B

© Edwards Limited 2013. All rights reserved.

Edwards and the Edwards logo are trade marks of Edwards Limited.