



EDO Scroll Pump

INSTRUCTION MANUAL

Copyright notice

©Edwards Limited 2021. All rights reserved.

Trademark credit

Edwards and the Edwards logo are trademarks of Edwards Limited, Innovation Drive, Burgess Hill, West Sussex RH15 9TW.

Associated publication

| Publication title | Publication number |
|--|--------------------|
| Vacuum Pump and Vacuum Systems Safety Manual | P40040100 |

Disclaimer

The content of this manual may change from time to time without notice. We accept no liability for any errors that may appear in this manual nor do we make any expressed or implied warranties regarding the content. As far as practical we have ensured that the products have been designed and constructed to be safe and without risks when properly installed and used in accordance with their operating instructions.

We accept no liability for loss of profit, loss of market or any other indirect or consequential loss whatsoever.

Product warranty and limit of liability are dealt with in our standard terms and conditions of sale or negotiated contract under which this document is supplied.

You must use this product as described in this manual. Read the manual before you install, operate, or maintain the product.

Contents

| | |
|---|-----------|
| 1. Safety and compliance. | 6 |
| 1.1 Definition of Warnings and Cautions. | 6 |
| 1.1.1 Safety symbols. | 7 |
| 2. Description. | 8 |
| 2.1 Gas ballast system. | 8 |
| 2.2 Cooling system. | 8 |
| 2.3 Safe area operation. | 9 |
| 3. Technical data. | 10 |
| 3.1 General technical data. | 10 |
| 3.2 Materials of construction. | 12 |
| 3.3 Lubrication system. | 13 |
| 4. Storage. | 14 |
| 5. Installation. | 15 |
| 5.1 Safety. | 15 |
| 5.2 Unpack and inspect. | 15 |
| 5.3 Locate the pump. | 16 |
| 5.4 Electrical installation. | 16 |
| 5.4.1 Electrical setup of pump. | 17 |
| 5.5 Earth (Ground) connection. | 19 |
| 5.6 Check the direction of pump rotation. | 19 |
| 5.7 Connect the pump inlet and pump outlet. | 20 |
| 5.7.1 Connect the pump to the process system. | 20 |
| 5.7.2 Connect the pump outlet. | 21 |
| 5.8 Leak test the installation. | 21 |
| 5.9 Commission the pump. | 22 |
| 6. Operation. | 23 |
| 6.1 Start the pump. | 23 |
| 6.1.1 Prestart checks. | 23 |
| 6.1.2 Startup. | 24 |
| 6.2 Shut down the pump. | 24 |
| 7. Maintenance. | 26 |
| 7.1 Safety. | 26 |
| 7.2 Maintenance plan. | 27 |
| 7.2.1 Clean the external fan cover. | 27 |

| | | |
|------------|--|-----------|
| 7.2.2 | Inspect the system installation. | 27 |
| 7.2.3 | Re-greasing the Orbit scroll bearings. | 28 |
| 7.2.4 | Tip seal replacement. | 29 |
| 7.3 | Overhaul the pump. | 29 |
| 8. | Fault finding. | 30 |
| 9. | Disposal. | 34 |
| 10. | Spares. | 35 |
| 11. | Accessories. | 36 |
| 12. | Service. | 37 |
| 12.1 | Return the equipment or components for service | 37 |

List of Figures

| | |
|---|----|
| Figure 1: Pump connections. | 8 |
| Figure 2: Dimensions. | 11 |
| Figure 3: Electrical setup of pump. | 18 |
| Figure 4: Secondary Earth (ground). | 19 |
| Figure 5: Gas ballast - closed. | 24 |
| Figure 6: Gas ballast - open. | 24 |
| Figure 7: Re-greasing the OS bearing. | 29 |

1. Safety and compliance

1.1 Definition of Warnings and Cautions

NOTICE:

Obligation to Provide Information

Read and follow these instructions carefully before installing and commissioning to ensure optimum and safe operation right from the start.



Safe and proper operation is guaranteed when used correctly and in accordance with the instructions contained in these operating instructions. Please read all safety instructions in this section and the rest of this manual carefully and make sure that these instructions are followed. The device may be operated and maintained only by trained personnel in the proper condition and as described in the operating instructions. Also observe local and state requirements and regulations. If you have any questions regarding safety, operation or maintenance of the device, please contact our nearest subsidiary.



DANGER:

Danger indicates a hazard with a high level of risk which, if not avoided, will result in death or serious injury.



WARNING:

Warning indicates a hazard with a medium level of risk which, if not avoided, could result in death or serious injury.



CAUTION:

Caution indicates a hazard with a low level of risk which, if not avoided, could result in minor or moderate injury.



NOTICE:

Information about properties or instructions for an action which, if ignored, will cause damage to the pump or the system.









We reserve the right to change the design and the stated data. The illustrations are not binding.

Keep the instructions for future use.

1.1.1 Safety symbols

The safety symbols on the products show the areas where care and attention is necessary.

The safety symbols that follow are used on the product or in the product documentation.

| | |
|---|--|
|  | <p>Warning/Caution</p> <p>An appropriate safety instruction must be followed or caution to a potential hazard exists.</p> |
|  | <p>Warning - Heavy object</p> <p>Identifies a possible hazard from a heavy object.</p> |
|  | <p>Warning - Dangerous voltage</p> <p>Identifies possible hazards from dangerous voltages.</p> |
|  | <p>Warning - Hot surfaces</p> <p>Identifies a potential hazard from a hot surface.</p> |
|  | <p>Warning - Do not step</p> <p>Personnel must not step onto the marked area.</p> |
|  | <p>Warning - Protective earth (ground)</p> <p>Earth point for electrical equipment.</p> |
|  | <p>WEEE symbol</p> <p>The equipment must be discarded carefully. Obey local and national regulations for disposal of this equipment.</p> |
|  | <p>Warning - Use protective equipment</p> <p>Use appropriate protective equipment for the task.</p> |

2. Description

The EDO pump are rugged, reliable dry vacuum pumps designed for general vacuum use. The pumps are suitable for a wide range of industrial applications.

The pump is a directly driven scroll pump and uses a standard industrial 3-phase motor.

The motor shaft protrudes out of the scroll stator (i.e. fixed scroll) and has the scroll rotor (i.e. orbiting scroll) attached on one side. A cooling fan is attached to the other end of the motor shaft. The patented scroll mechanism is a three-stage compression design with:

- two parallel inlet turns in the first stage
- a single turn in the second stage
- a single turn but with half of the scroll height in the third stage.

To limit the compression at higher inlet pressures by the pump, there are two blow off valves in between the stages.

The pumps have rubber isolation mounts to secure the pump in its operating position. Refer to [Figure: Dimensions](#).

2.1 Gas ballast system

The pump has a gas ballast system to pump high vapour loads. The gas ballast is supplied into the pump to prevent condensation of the vapour carried by the pumped gases. Gas ballast is manually operated. Refer to [Pre-start checks](#) on page 23.

2.2 Cooling system

The pump is air cooled. The pump is designed to keep the motor and bearing at a temperature lower than the process fluid and reduce the maintenance cost. The motor cooling fan cools the motor.

Figure 1 Pump connections

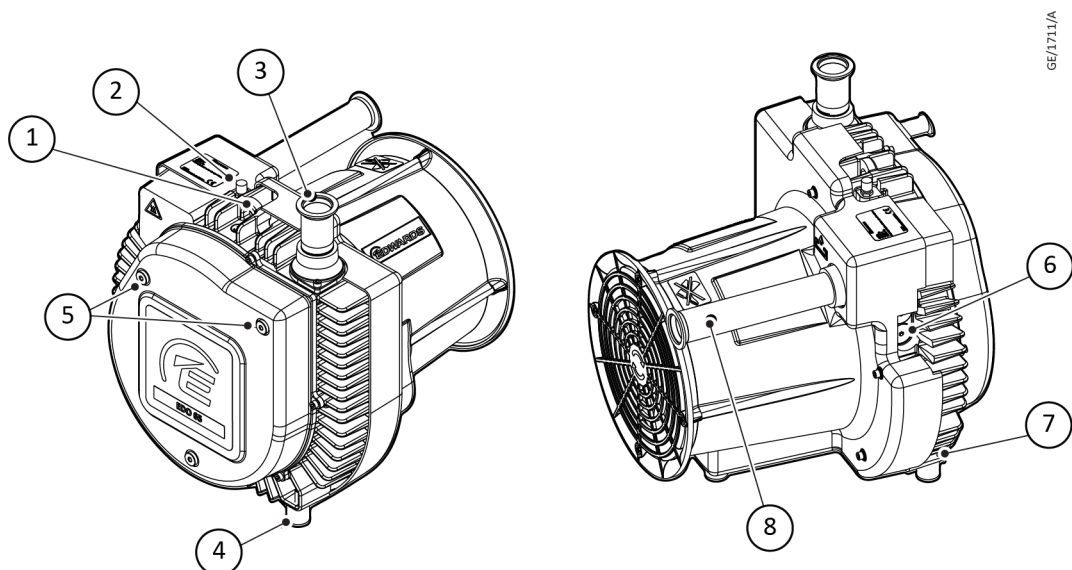

- | | |
|---------------------------------------|--------------------------------|
| <i>1. Lifting points</i> | <i>2. Gas ballast</i> |
| <i>3. Pump inlet</i> | <i>4. AV foot mount</i> |
| <i>5. Pressure measurement points</i> | <i>6. Blow off valve seats</i> |
| <i>7. Earthing points</i> | <i>8. Pump outlet</i> |

2.3 Safe area operation

The pump is not suitable for hazardous gases. The pump must only be used for non-hazardous applications.

3. Technical data

3.1 General technical data

Table 1 General technical data

| Parameter | Data |
|--|---|
| Dimensions | Refer to Figure: Dimensions |
| Weight (excluding packaging) | Approximately 53 kg, 116.84 lb |
| Maximum shaft speed | Approximately 3000 rev.min ⁻¹ |
| Protection grade | IP54* |
| Pump connection (Refer to Table: Inlet/outlet connection kit) | |
| ▪ Pump inlet connection | NW/KF 40 (standard fitting) |
| ▪ Pump outlet connection | NPT 1¼" FEMALE (available as an option) |
| Ambient operating temperature range | 0 to 40 °C, 32 to 104 °F |
| Maximum ambient operating humidity | 90% RH |
| Minimum air inlet temperature | 10 °C, 50 °F |
| Maximum air inlet temperature | 40 °C, 104 °F |
| Maximum outlet pressure | 1200 mbar(a), 900 torr |

**If the fan cowl is removed, internal components have lower IP ratings. Operation without fan cowl is not recommended.*

Figure 2 Dimensions

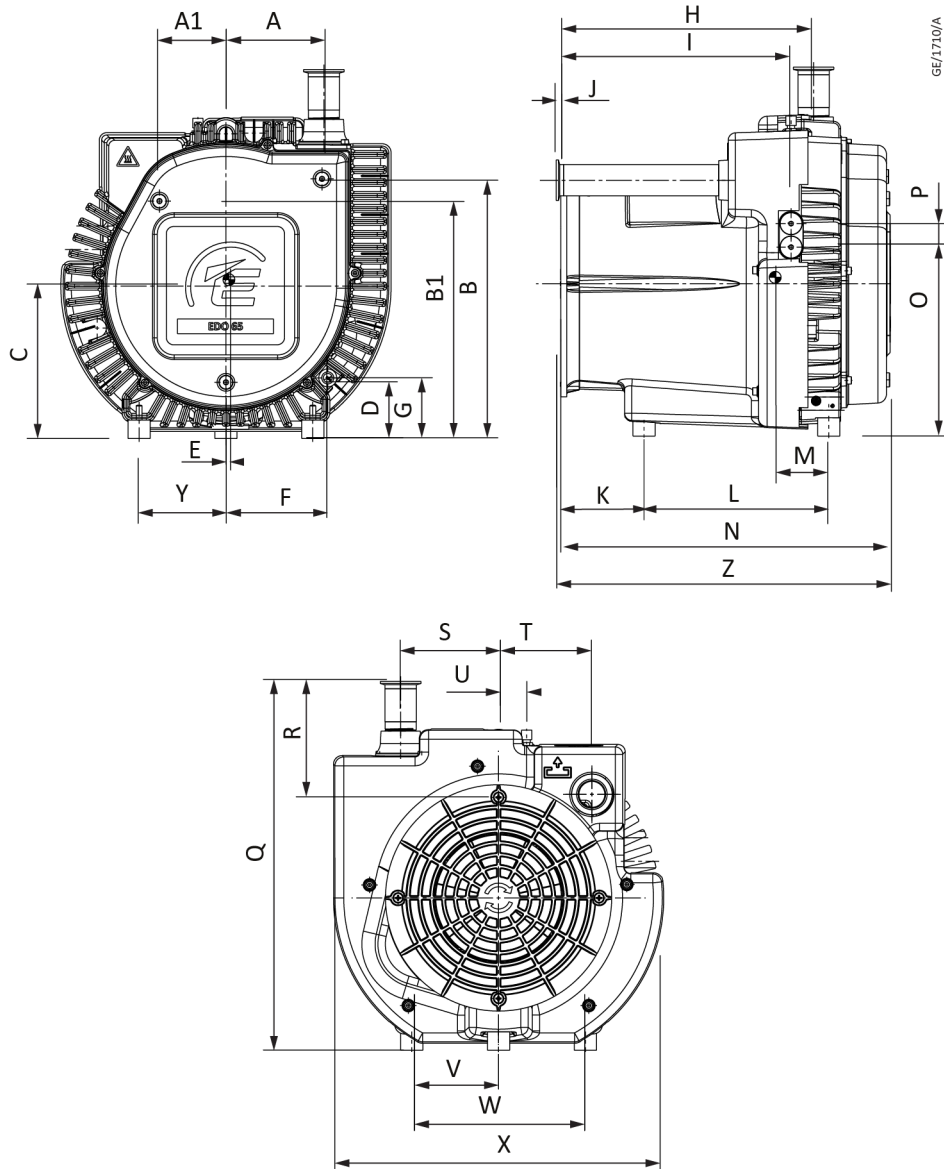

| Dimension | Values | | Dimension | Values | | Dimension | Values | |
|-----------|--------|--------|-----------|--------|--------|-----------|--------|--------|
| | mm | inches | | mm | inches | | mm | inches |
| A | 130 | 5.12 | I | 311.7 | 12.27 | S | 132.5 | 5.22 |
| A1 | 90 | 3.54 | J | 6.1 | 0.24 | T | 126.3 | 4.97 |
| B | 351 | 13.82 | K | 112.7 | 4.44 | U | 38 | 1.5 |
| B1 | 321 | 12.6 | L | 250 | 9.84 | V | 117.5 | 4.63 |
| C | 214.7 | 8.4 | M | 72.5 | 2.8 | W | 235 | 9.25 |
| D | 76 | 3 | N | 446 | 17.56 | X | 446.9 | 17.6 |
| E | 4 | 0.15 | O | 255.5 | 10 | Y | 117.5 | 4.6 |
| F | 137.7 | 5.42 | P | 31.8 | 1.25 | Z | 451.8 | 17.8 |
| G | 82 | 3.2 | Q | 498.8 | 19.6 | | | |
| H | 342.2 | 13.47 | R | 152.8 | 6 | | | |

3.2 Materials of construction

Table 2 Materials of construction

| Component | Material |
|--|---|
| Fixed scroll Orbit scroll Inlet Outlet Front cover OS cover | Cast aluminium |
| Inlet valve | PBT 30% glass filled |
| Anti-rotation device | Nylon 30% glass filled |
| Cowl Cowling end | Injection moulded - Polypropylene |
| Shaft | Steel |
| BOV valve stems | Stainless steel |
| Tip seals | PTFE |
| Other seals | Fluoroelastomer, Nitrile |
| Inlet filter | Felt frame glued in with synthetic. Secondary steel frame |

Table 3 General electrical data

| Voltage [V] | Voltage tolerance [%] | Frequency [Hz] | Frequency tolerance [%] | Approval |
|-------------------------|---|------------------------|-------------------------|----------|
| 200 | ±10 | 50 | - 5 / + 3 | IEC |
| 230 | ±10 | 50 | - 5 / + 3 | IEC |
| 400 | ±10 | 50 | - 5 / + 3 | IEC |
| 500 | ±10 | 50 | - 5 / + 3 | IEC |
| Description | Part number | Voltage range grouping | | |
| EDO65 | A50871958 | 230VD / 400VY | | |
| | A50871959 | 200VD / 345VY | | |
| | A50871960 | 500VY | | |
| Description | Rating | | | |
| Frequency | 50 Hz | | | |
| Wiring configuration | 3-wire plus Earth (ground) | | | |
| Voltage tolerance range | +/- 10% | | | |
| Installation category | II (IEC 60664-1) | | | |
| Efficiency class | IE3 (Premium efficiency) to EN 60034-30 | | | |

Table 4 Electrical supplies

| Parameter | Data |
|------------------------------|-------------|
| Pump-electrical motor rating | 1.5 kW/2 HP |

| Parameter | Data |
|--|-----------------------------------|
| Fuse rating | 3-phase, Type C |
| Maximum load current | |
| ▪ 200 VD 50 Hz | 7.3 A |
| ▪ 230 VD 50 Hz | 6.3 A |
| ▪ 345 VY 50 Hz | 4.2 A |
| ▪ 400 VY 50 Hz | 3.6 A |
| ▪ 500 VY 50 Hz | 2.9 A |
| Typical continuous A-weighted sound pressure level at 50 Hz* | <79 dB(A) |
| Maximum pumping speed | 65 m ³ h ⁻¹ |
| Ultimate pressure (Gas ballast closed) | 1.5 ± 0.5 mbar |
| Ultimate pressure (Gas ballast open) | 2.5 ± 0.5 mbar |

*The noise level was measured in accordance with ISO2151 and with the pump running at ultimate pressure. Running the pump at higher inlet pressures will increase the noise level. Use appropriate ear protection.

 **Note:**

We recommend you to fit a Residual current device (RCD 35/003/4) in the supply circuit.

3.3 Lubrication system

 **Note:**

Material Safety Data Sheets for the recommended grease given in the sections below are available on request.

High vacuum bearings

Table 5 Bearing lubrication data

| Parameter | Item number |
|-----------------|-------------|
| Required grease | 2236232060 |

4. Storage

Store the pump as follows:

1. Make sure that the pump is shut down as given in [Shut down the pump](#) on page 24, and disconnect the pump from the electrical supply.
2. Disconnect the pump inlet and outlet from your process and exhaust pipelines.
3. Attach blanking plates to the pump inlet and pump outlet.
4. Place protective covers over the pump service connection points.
5. Store the pump in a clean dry condition until required.
6. When required for use, prepare and install the pump as given in [Installation](#) on page 15.

5. Installation

5.1 Safety



WARNING: INSTALLATION SAFETY

Risk of injury to people and damage to equipment. Obey the safety instructions given below and take note of appropriate precautions. There must be sufficient lighting for the personnel to read all the relevant safety labels on the system.

Potential hazards on the dry pumps include electricity, hot surfaces, process chemicals.

Detailed safety information is given in our Safety Manual for Vacuum Pumps and Vacuum Systems. This publication is available on request.

- A suitably trained and supervised technician must install the pump. We can train the users to conduct the tasks described in this manual, contact us or the local service centre for more information.
- Do not remove the temporary cover or blanking plate from the dry pump inlet and exhaust until prepared to connect the dry pump to the vacuum or exhaust extraction system. Do not operate the pump unless the inlet and exhaust are connected to the vacuum and exhaust extraction system.
- Make sure that the installation technician knows the safety procedures related to the products pumped. Wear the appropriate safety clothing when you do work related to contaminated components.
- Make sure that all the required components of the correct type are available before you start.
- Disconnect the components in the process system from the electrical supply to prevent accidental operation.
- The electrical supply is a potentially hazardous energy source. Lockout and tagout any supply source before you do maintenance.
- Obey all national and local rules and safety regulations when you install the dry pump.
- Route and secure cables, hoses and pipework during installation to avoid possible risk of trips.
- Make sure that the installation area is clean and free from debris and contamination, such as oil, before you locate the pump.

5.2 Unpack and inspect



WARNING: HEAVY OBJECT

Risk of physical injury. Use suitable lifting equipment.

The pump is supplied on a wooden pallet covered with a cardboard and requires equipment to lift the pump.

1. Use a forklift truck or a pallet truck to place the pallet in a convenient position.
2. Remove the packing materials. It is recommended that you retain all packing materials for use if the pump is to be returned for service.
3. If the pump is damaged, notify the supplier and the carrier in writing within three days; state the item number of the pump together with the order number and the supplier's invoice number. Retain all packing materials for inspection. Do not use the pump if it is damaged.
4. If the pump is not to be used immediately, store in suitable conditions as given in [Storage](#) on page 14.

5.3 Locate the pump



WARNING: HEAVY OBJECT

Risk of physical injury. Use suitable lifting equipment. Do not push/pull the pump. Do not stand on or place any heavy objects on any part of the pump.

Refer to the installation drawing for information about centre of gravity.

To lift the pump, each pump has a lifting eye. Make sure that the lifting eye is used when you lift the pump.

1. Remove all the bolts which secure the pump to the pallet.
2. Attach suitable lifting equipment to the lifting eye to move the pump.
3. Locate the pump on a firm, level surface. Make sure that the surface is clean and free from debris and contamination (such as oil).
4. The pump can be installed and bolted down directly to the floor or installed on a stable support frame. To secure the pump in position, install the four M8 bolts to the fixing-holes in the mounting feet (if required).
5. Make sure that the location of the pump and the intended routing of connecting parts i.e. process line, exhaust line and power cables do not have any physical hazards, for example, trip hazards.

5.4 Electrical installation



WARNING: HAZARDOUS VOLTAGE

Risk of electric shock. You must provide suitable strain relief on the electrical supply cable. If you do not, the cable (or wires in the cable) may become disconnected from the pump motor and there may be a risk of injury or death by electric shock.

WARNING: HAZARDOUS VOLTAGE

The pump must be electrically installed in accordance with regional and local codes, conforming to local and national safety requirements. The pump must be connected to a suitably fused and protected electrical supply and a suitable Earth (ground) point.



Isolate the electrical supply before you disconnect the electrical supply cable from the dry pump. The power wiring to the pump must be properly protected.

You must know that the pump will restart automatically when the electrical supply is restored after an electrical supply failure. To prevent the automatic restart of the pump motor connect the pump to the electrical supply through suitable control equipment which must be reset manually after an electrical supply failure.

If the pump is to be used on the floor of a work area, position the power lead, exhaust and inlet hoses with care. Make sure that the personnel in the area knows all the obstructions around the pump. Be careful, that the power cable is permanently connected to the pump.

CAUTION: DAMAGE TO MOTOR

Risk of minor injury and damage to equipment. Make sure that the motor is configured correctly for your electrical supply. If you operate the pump when the motor is not configured correctly for the electrical supply, you will damage the motor.

Make sure that the access of the power cable to the pump is not obstructed when you locate the pump.

Connect the electrical supply to the pump through a suitable circuit breaker with appropriate type C fuses. A circuit breaker must have thermal over-current protection. Adjust the over-current protection to suite your installation. The full-load current ratings are shown in [Table: Electrical supplies](#). Make sure that the fuse is suitable for the starting currents of your installation (Fuse type C).

The pump will start automatically when the electrical supply is turned on. If you do not want the pump to automatically restart, connect the electrical supply to the pump motor through a control equipment which must be manually reset after an electrical supply interruption.

Refer to [Earth \(Ground\) connection](#) on page 19 where the Earth (ground) point is located. Using the Earth (ground) point is mandatory.

The only electrical connections necessary is that of the customer supply cable and the mandatory earth connection shown in [Figure: Electrical setup of pump](#).

5.4.1 Electrical setup of pump

Refer to [Figure: Electrical setup of pump](#).

For Low voltage - Triangle connection (200 V - 230 V)

- U1 + W2 - Connected together into L1
- V1 + U2 - Connected together into L3
- W1 + V2 - Connected together into L2

For High voltage - Star connection (345 V - 500 V)

- U1 - Connect into L1
- V1 - Connect into L3
- W1 - Connect into L2
- U2 + V2 + W2 - Connected together and insulated

Change L2 with L3 for counter direction of rotation.

Figure 3 Electrical setup of pump

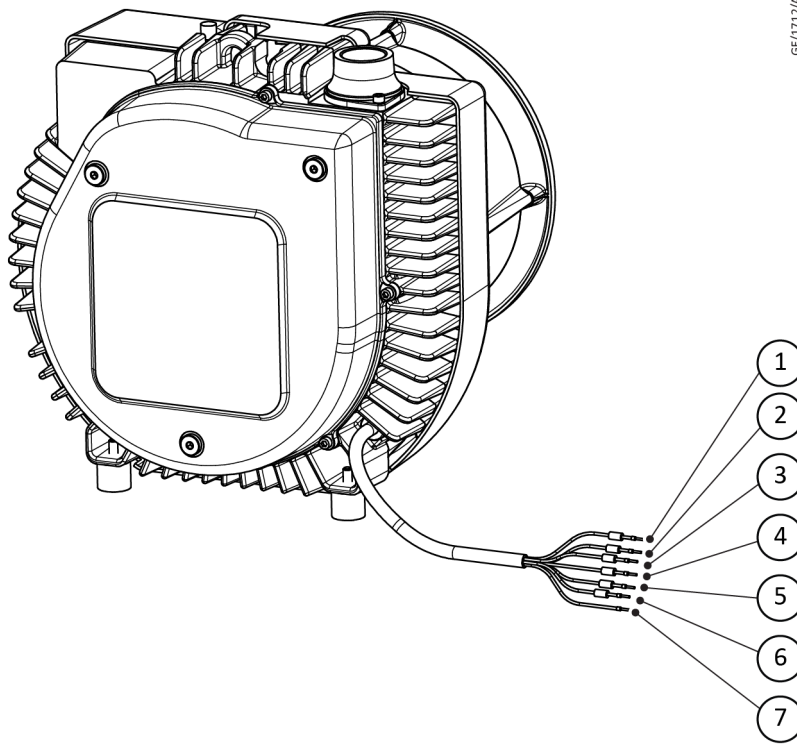

- | | |
|----------|-------|
| 1. U1 | 2. W2 |
| 3. V1 | 4. U2 |
| 5. W1 | 6. V2 |
| 7. Earth | |

- Power supply cable length is approximately 1.5 m

| Motor type | Voltage | Tolerance | Phase | Connection | Frequency |
|------------|---------|-----------|-------|------------|-----------|
| 1 | 230 V | ±10% | 3 | Δ | 50 Hz |
| | 400 V | ±10% | 3 | Y | 50 Hz |
| 2 | 200 V | ±10% | 3 | Δ | 50 Hz |
| | 345 V | ±10% | 3 | Y | 50 Hz |
| 3 | 500 V | ±10% | 3 | Y | 50 Hz |

Voltage range grouping for 50 Hz

- 230VD / 400VY
- 200VD / 345VY
- 500VY

5.5 Earth (Ground) connection

It is mandatory that the pump is connected to a suitable factory/plant Earth (ground) and a secondary earth grounding using the same location as shown in *Figure: Secondary Earth (ground)*.

 **Note:**

The exhaust /inlet tubes are not suitable earthing points.

Figure 4 Secondary Earth (ground)

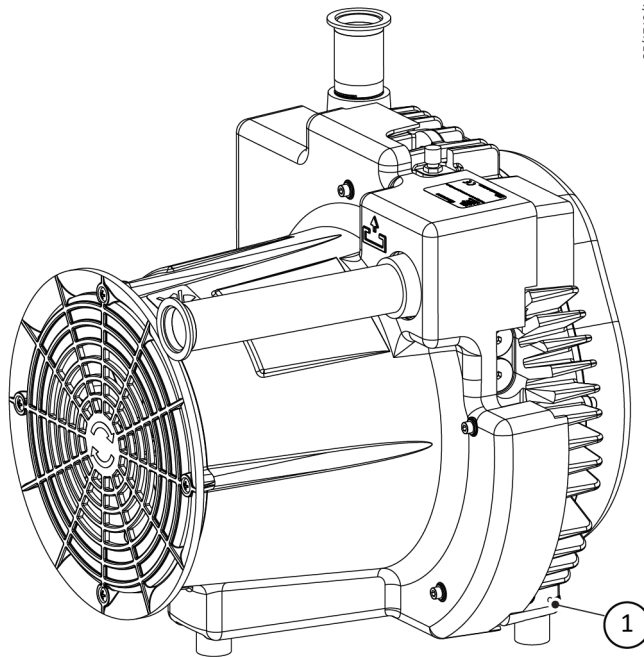

1. Mandatory secondary earth

5.6 Check the direction of pump rotation

WARNING: PRESSURISED PIPING



Risk of injury or damage to equipment. Make sure that the direction of rotation of the pump is correct before you operate the pump. If you do not, and the pump direction of rotation is incorrect, the inlet pipeline will be pressurised and may be damaged and there will be a risk of injury to people or explosion or fire.

 **Note:**

If you cannot easily see the cooling fan to determine its direction of rotation, see the blanking plate on the pump inlet. If the blanking plate lifts from the inlet when you switch on the pump, the direction of rotation is incorrect.

1. Remove the blanking cap from the pump inlet, then remove the blanking cap from the pump outlet.
2. Watch the cooling fan through a grid in the cooling air inlet, switch on the pump for one or two seconds, then switch the pump off.

3. If the cooling fan does not rotate in the correct direction shown by the arrow on the cover:
 - A. Isolate the pump from the electrical supply.
 - B. Reverse the wire marked L2 with the wire marked L3 to change the direction of pump rotation. Refer to *Figure: Electrical setup of pump*.
 - C. Repeat Step 2 to make sure that the direction of rotation is now correct.

5.7 Connect the pump inlet and pump outlet

WARNING: HAZARDOUS GASES



Risk of injury or death. Take all necessary safety precautions when you pump toxic gases. If you do not, there will be a danger of injury or death to people.
Risk of inhalation injury. Make sure that your system can provide sufficient gas ballast and/or inlet purge to dilute toxic gases to safe limits. If you do not, there will be a risk of emission of hazardous gases.

WARNING: HIGH PRESSURE IN PIPELINE



Risk of injury or damage to equipment. When the pump is switched off, gas will flow in reverse direction through the pump and there will be a rapid pressure rise in the inlet pipeline and your process system. Take sufficient protection (such as a fast-acting inlet isolation valve or an outlet check valve) to protect adjacent devices.

CAUTION: GASEOUS FUMES



Risk of minor injury or damage to equipment. At high temperature (if more than 250 °C) the tip seal wear product will begin to decompose, giving rise to gaseous fumes that can produce unpleasant symptoms.

5.7.1 Connect the pump to the process system

When you connect the pump to the process system:

- Support process pipelines to stop the transmission of stress to pipeline joints.
- Use a flexible connection in the pipeline (from the process system to the pump) to reduce vibration and stress in the system pipelines.
- You must be able to isolate the pump from the atmosphere and from your process system if you have pumped or produced dangerous chemicals.
- On very dusty applications, include an inlet filter in the inlet pipeline to minimise the entry of dust into the pump.
- To get the best pumping speed, make sure that the pipeline which connects the process system to the pump is as short as possible and has an internal diameter not less than the pump inlet.
- Do not allow debris (such as weld slag) to get into the pump during operation.
- If necessary, contact us or your supplier for advice on the inlet isolation valves, outlet check valves or other components suitable for your application and system design.

Procedure to connect an inlet of the pump to your process system is as follows:

1. Refer to *Figure: Pump connections* for inlet and outlet connection details. Remove cap from the pump inlet.
2. Use a flexible pipeline to connect the pump inlet to your vacuum system.

5.7.2 Connect the pump outlet



WARNING: HAZARDOUS GASES

Risk of inhalation injury. Connect the exhaust to a suitable treatment plant to prevent the discharge of dangerous gases or vapours to the surrounding atmosphere.



WARNING: HIGH PRESSURE IN PIPELINE

Risk of damage to equipment. Use safety devices to prevent operation of the pump when the exhaust pipeline is restricted or blocked. If you do not, the exhaust pipeline may become over-pressurised and may burst.



CAUTION: CONDENSATE DRAINAGE

Risk of damage to equipment. Install an outlet catchpot to prevent the drainage of condensate back into the pump. If you do not, condensate which drains back into the pump may damage it or cause it to seize.

Design your exhaust pipeline system such that the pressure in the pipeline during pump operation is less than 1.2 bar absolute (1.2×10^5 Pa, 900 torr). If the pressure in the pipeline is higher than this pressure, the pump will operate at a high temperature and may trip because of excessive electrical current consumption.

Install flexible bellows in the exhaust pipeline to reduce the transmission of vibration and to prevent loading of the coupling joints. If you use flexible bellows, make sure that the bellows have a maximum pressure rating which is greater than the highest pressure that can be generated in your system, and which can withstand the maximum temperatures that can be generated by your process conditions.

A small amount of tip seal wear product may collect in the exhaust duct of the pump. The dust may be blown out with an initial burst of air after the pump has been vented.

Procedure to connect the pump outlet to your exhaust pipeline is as follows:

1. Refer to *Figure: Pump connections* for inlet and outlet connection details. Remove the blanking cap from the pump outlet.
2. Use a flexible pipeline to connect the pump outlet to your exhaust pipeline.

5.8 Leak test the installation



WARNING: SYSTEM LEAKAGE

Risk of injury or damage to equipment. Leak test the system after installation and maintenance. Seal any leaks found to prevent the leakage of dangerous substances out of the system and leakage of air into the system.

Leak test the system after installation and seal all the leaks found. Substances which leak from the system may be dangerous to people and there may be a danger of explosion if air leaks into the system.

The pump is not designed to be leak-tight. The pump is equipped with the non-return valve on the inlet. The required leak rate for your system will depend on your safety and process requirement.

5.9 Commission the pump

1. Isolate the pump from the process system.
2. Make sure that the gas ballast is closed.
3. Switch on the electrical supply to start the pump.
4. Make sure that the direction of rotation of the pump is correct before you operate the pump. Refer to [Check the direction of pump rotation](#) on page 19.
5. Let the pump operate for approximately 60 minutes to stabilise the pump operating temperature.
6. Make sure that the pump operating temperature is in the range of 10 to 75 °C (50 to 167 °F).

6. Operation

WARNING: HOT SURFACES



Risk of burns from hot surfaces. During operation, some parts of the pump become hot, these areas are identified by 'hot surface' labels. Do not touch these areas of the pump and avoid accidental contact between these areas of the pump and electrical cables and wires.

WARNING: EXPOSURE TO VACUUM



Do not operate the pump with the exhaust pipeline blocked.
Do not expose any part of the human body to the vacuum as this could result in injury or death.

WARNING: SYSTEM SHUTDOWN



Make sure that the cooling air flow around the pump motor is not restricted. If the air flow is restricted, the motor will get hotter than normal during pump operation. This may result in reduced reliability and/or damage and/or the risk of the motor thermal switch shutting down the system.

Note:

The pump is for indoor use only (IP54).

6.1 Start the pump

CAUTION: VAPOUR CONDENSATION IN PUMP



Risk of damage to equipment. Let the pump to warm up and use full gas ballast and inlet purge (if installed) before you pump condensable vapours. If you do not, the vapours may condense in the pump and corrode or damage the pump.

6.1.1 Prestart checks

Make sure that the pump is correctly installed, as given in [Installation](#) on page 15.

Gas ballast control

Use the gas ballast control to introduce air into the final stage of the pump. The gas ballast will reduce the condensation of vapours in the pump.

Gas ballast OFF (closed in clockwise direction). Use this setting to:

- Achieve ultimate vacuum
- Pump dry gases.

Figure 5 Gas ballast - closed

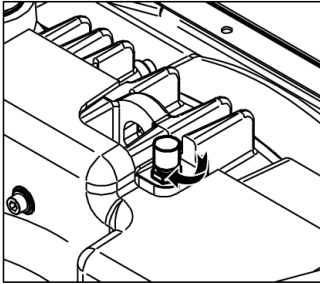

Gas ballast ON (opened in counter-clockwise direction). Use this setting to:

- Pump low concentrations of condensable vapours
- Remove all the contamination from the pump.

Figure 6 Gas ballast - open

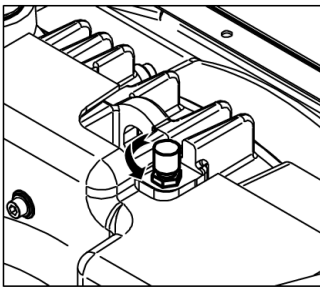

6.1.2 Startup

1. Make sure that the isolation valves in the pump inlet and exhaust are in the correct positions.
2. Switch on the electrical supply to start the pump.
3. Let the pump run to achieve normal operating temperature.
4. Run the pump in conformity with this instruction manual.

6.2 Shut down the pump



CAUTION: VAPOUR CONDENSATION IN PUMP

Risk of damage to equipment. Purge the pump before you shut it down. If you do not, process vapours may condense in the pump and corrode or damage it.

1. If the pump needs to be shut down prior to a period of storage, remove process gases by running on high flow gas ballast or by inlet purge (if fitted).
2. Close the vacuum system isolation valve to prevent suck-back into the vacuum system (where installed).
3. Switch off the electrical supply of the pump.

4. There may be some back rotation of the pump after shut down – this is normal due to pressure equalisation when the inlet valve closes.

7. Maintenance

7.1 Safety



WARNING: MAINTENANCE SAFETY

Risk of injury or damage to equipment. Obey the safety instructions given below and take note of appropriate precautions. If you do not, you can cause injury to people and damage to equipment.



WARNING: HAZARDOUS VOLTAGES

Risk of electric shock. Only personnel specially trained to do electrical maintenance should attempt troubleshooting in the electrical enclosures. These enclosures contain hazardous voltages and are not operator areas.



WARNING: DANGEROUS SUBSTANCE

Risk of asphyxiation. Do not touch or inhale the thermal breakdown products of fluorinated materials in the pump if the pump has been heated to 260 °C and above. Fluorinated materials are safe in normal use but can decompose into very dangerous substances (which may include hydrofluoric acid) if heated to 260 °C and above. The pump may become too hot if it was misused or if it was in a fire. Safety Data Sheets for fluorinated materials used in the pump are available on request, contact us or the supplier.



WARNING: ACCIDENTAL OPERATION

Risk of injury or damage to equipment. Disconnect the pump and other components from the electrical supply to prevent accidental operation.

1. Make sure that the maintenance technician knows the safety procedures related to the synthetic oils and greases used, and the products pumped.
2. Pump must be switched off, stationary and must have cooled to a safe temperature before you move or relocate.
3. Isolate and lock out the pump and other components in the process system from the electrical supply so that it cannot be operated accidentally.
4. Wear appropriate safety clothing when you work with contaminated components, grease and pump oil. Disassemble and clean the contaminated components inside a fume cupboard.
5. Use suitable lifting equipment and wear safety shoes when you replace the pump motor or the pump module.
6. Re-check the pump rotation direction if the electrical supply is disconnected.
7. Do not reuse O-rings or gaskets if they are damaged. Replacement intervals changes as the application changes.
8. Take care to prevent damage of sealing-faces.

9. Do the leak test of the system after installation is completed and seal all the leaks found to prevent leakage of dangerous substances out of the system and leakage of air into the system. See [Leak test the installation](#) on page 21.

7.2 Maintenance plan

The plan in [Table: Maintenance plan](#) gives the information of maintenance operations we recommend to apply within normal operation. Instructions for each operation are given in the section shown. In practise, the frequency of maintenance is dependent on your process. Adjust the maintenance plan according to your experience.

In harsh processes, the frequency of maintenance operations can be increased.

Table 6 Maintenance plan

| Operation | Frequency |
|--|--------------|
| Clean the external fan cover on page 27 | Monthly |
| Inspect the system installation on page 27 | Monthly |
| Re-greasing the Orbit Scroll bearings on page 28 | 4000 hours** |
| Tip seal replacement on page 29 | 4000 hours** |
| Drain the pump | As needed |

**4000 hours or 1 year whichever comes first.

7.2.1 Clean the external fan cover



CAUTION: RESTRICTED AIR FLOW

Risk of minor injury or damage to equipment. If the fan cover and pump body are not kept clean, the air flow over the pump can be restricted and the pump may become too hot.

Procedure to clean the external fan cover is as follows:

1. Switch off the pump and disconnect it from the electrical supply.
2. Use a dry cloth and a soft brush to remove dirt and deposits from the fan cover and pump body.

7.2.2 Inspect the system installation

 **Note:**

It is recommended to do the inspection of the system at regular intervals.

1. Do the inspection of all the system pipelines and connections. Make sure that they are not damaged or corroded and are leak-tight. Repair or replace any damaged or corroded component and seal all the leaks found.
2. Do the inspection of all the electrical cables and replace if they are damaged or have become too hot.
3. Make sure that all the electrical connections are secure, tighten the loose connections.

7.2.3 Re-greasing the Orbit scroll bearings

The bearings need to be re-lubricated after specified period to replace grease that has been deteriorated, leaked away or become contaminated.

Refer to [Figure: Re-greasing the OS bearings](#) and do the following procedure to re-grease the OS bearings:

1. Switch off the pump and isolate the electrical supply. Allow the pump to cool down to safe temperature.
2. Set the gas ballast to ON (open in counter-clockwise direction) and vent the pump.
3. Remove the five front cover retaining screws.
4. Remove the pump front cover.
5. Remove the one screw which secure the Orbit scroll cover.
6. Attach the syringe with the syringe adapter firmly into the hole. Make sure that the O-ring is not damaged.
7. Push the entire content of the syringe into the hole. Apply additional force to counter the resistance.
8. Pull the syringe out with the adaptor.
9. Tighten the one fixing screw onto the orbit scroll assembly with a tightening torque of 4 Nm. Take care not to damage the O-ring.
10. Refit the front cover.
11. Tighten the five fixing screws progressively and evenly onto the housing assembly with a tightening torque of 8 Nm. Always torque nuts in a cross bolt tightening pattern.
12. Install the pump as described in [Installation](#) on page 15.
13. Make sure that the cooling fan rotate in the correct direction. If not refer to [Check the direction of pump rotation](#) on page 19.
14. Start the pump for 5 minutes. Stop the pump and allow to cool.

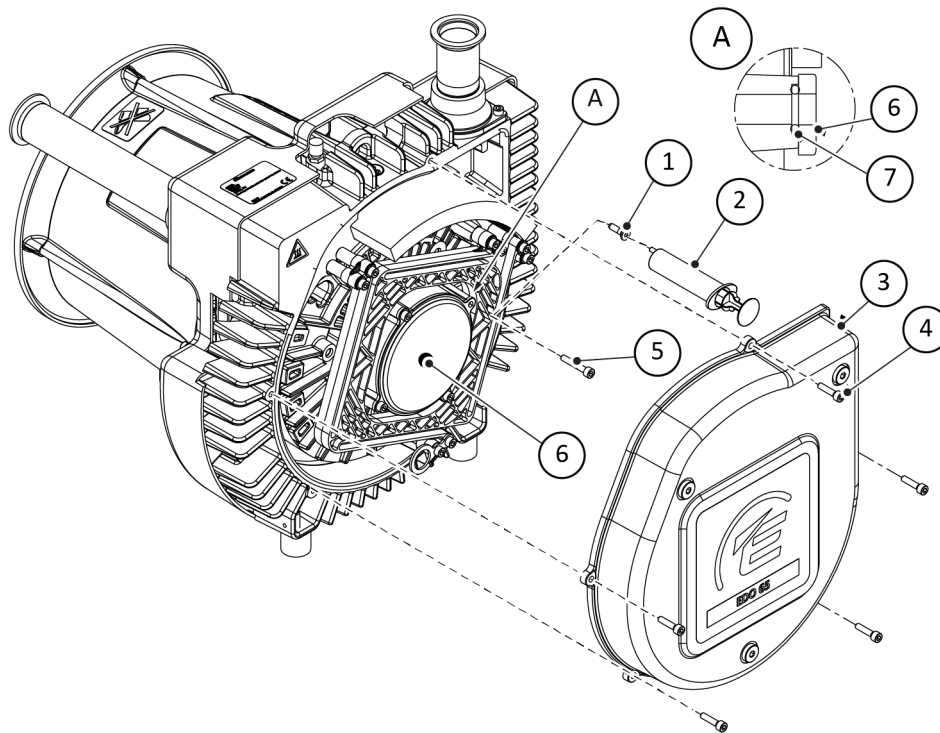
Figure 7 Re-greasing the OS bearing

GE/T1714/A

- | | |
|----------------------------|--------------------------------|
| 1. <i>Syringe adapter</i> | 2. <i>Syringe</i> |
| 3. <i>Pump front cover</i> | 4. <i>Front cover screw M6</i> |
| 5. <i>OS screw cover</i> | 6. <i>OS bearing cover</i> |
| 7. <i>O-ring</i> | |

7.2.4 Tip seal replacement

The tip seals need to be replaced after specified period if it is damaged. Refer to Tip seal replacement instruction manual (Publication number A50871840) for instructions to replace the tip seals.

7.3 Overhaul the pump

We recommend that the pump is given a major overhaul in STC after 32000 hours. Such an overhaul is outside the scope of this manual and must be done by service personnel qualified by us. Contact us or your supplier for more information.

8. Fault finding

| | |
|--------------|---|
| Fault | The pump does not operate |
| Cause | The pump is not connected to the electrical supply. |
| Remedy | The pump must be connected to a suitably fused and protected electrical supply. |
| Cause | The electrical supply voltage does not match the product requirements. |
| Remedy | Check the product label. Connect the pump to correct power supply. |
| Cause | The electrical connection type is wrong (“Δ or Y”). |
| Remedy | Check the product label. Use proper electrical connection type to connect the pump. |
| Cause | The pump motor is faulty. |
| Remedy | Make all the other appropriate checks in this table. If you have repaired any problem related to electrical connection and the pump still fails to operate, the pump may have been damaged, contact us or your supplier. |
| Cause | The pump is not able to start due to an internal fault. |
| Remedy | Make all the other appropriate checks in this table. If there is no other cause for failure of the pump to operate, contact us or your supplier. |
| Fault | The pump has failed to achieve the required performance |
| Cause | There is a leak in your vacuum system. |
| Remedy | Make sure that all process and exhaust connections are secure. Tighten the loose connections. Do the leak test of the system after installation/maintenance and seal all the leaks found. |
| Cause | Your vacuum fittings are dirty or damaged. |
| Remedy | Do the inspection of all the connections. Make sure that they are not dirty, corroded or damaged. Replace all the corroded or damaged parts. |
| Cause | The inlet filter is blocked. |
| Remedy | Do the inspection of the inlet filter. If there are excessive deposits lodged in the inlet filter, remove it and dispose safely in accordance with all local, national safety and environmental requirements. Install a new inlet filter. |
| Cause | The electrical connection type is wrong (“Y instead of Δ”). |
| Remedy | Check the product label. Use proper electrical connection type to connect the pump. |
| Cause | There is a blockage in the exhaust line. |

Remedy Do the inspection of the exhaust manifold. If there are any objects or restrictions, remove it and dispose safely in accordance with all local, national safety and environmental requirements.

Cause **The tip seal is worn.**

Remedy Make all the other appropriate checks in this table. If there is no other cause for poor performance of the pump, the tip seal may be too worn or damaged. Refer to Tip seal replacement instruction (Publication number 9824100040) for instructions to replace the tip seals.

Fault **The pump is noisy/the sound is not cohesive (inconsistent)**

Cause **Incorrect direction of rotation of the pump.**

Remedy Turn off the pump immediately and isolate the pump from the electrical supply. Reverse any two of the electrical supply phase-wires in the socket plug. Make sure that the direction of rotation of the pump is correct before you operate the pump again.

Cause **The bearings are damaged.**

Remedy If there is an audible clinging sound and the pump is overheating, bearings may be damaged. Switch off the pump immediately and contact us or your supplier.

Cause **The pump is contaminated with solid particles.**

Remedy If there is an audible clinging or rattling sound, but pump temperature is normal (maximum 65 °C on front cover), switch off the pump immediately. Remove the front cover and possible loose solid particles from internal space of the pump. If this action does not help, contact us or your supplier.

Cause **The anti-rotation device is damaged.**

Remedy If there is an audible regular pounding sound lasting for short time only, the anti-rotation device may be damaged. Switch off the pump immediately. Remove plastic enclosure front cover, the grey-coloured front cover and do the inspection of the anti-rotation device for any cracks/rupture. If you find any damage on the anti-rotation device contact us or your supplier.

Fault **The pump surface temperature is high (65°C+ on front cover)**

Cause **The ambient temperature is too high.**

Remedy Make sure that the dry pump is installed in a well-ventilated area.

Cause **There is no grease on the bearings.**

Remedy If the pump becomes too hot, the bearings may have no grease on them. Switch off the pump immediately and contact us or your supplier.

Cause **There is a blockage in the exhaust line.**

Remedy Do the inspection of the exhaust manifold. If there are any objects or restrictions, remove them and dispose safely in accordance with all local, national safety and environmental requirements.

Fault The pumping speed is poor

Cause The connecting pipelines are too small in diameter.

Remedy To get the best pumping speed, make sure that the pipeline which connects the process system to the pump has an internal diameter not less than the pump inlet.

Cause The connecting pipelines are too long.

Remedy To get the best pumping speed, make sure that the pipeline which connects the process system to the pump is as short as possible.

Cause The inlet filter is blocked.

Remedy Remove the plastic enclosure front cover, the grey-coloured front cover and do the inspection of the inlet filter. If there are excessive deposits lodged in the inlet filter, remove them and dispose safely in accordance with all local, national safety and environmental requirements. Install a new inlet filter.

Cause There is a blockage in the exhaust line.

Remedy Do the inspection of the exhaust manifold. If there are any objects or restrictions, remove them and dispose safely in accordance with all local, national safety and environmental requirements.

Fault The pump suddenly stops

Cause If the power supply fails, the pump will coast down to stop.

Remedy Renew the electrical supply. You can operate the pump again.

Cause The pump seized due to faulty shut down thermal snap switch.

Remedy Check the operating temperature of the pump. If the operating temperature is higher than 75 °C, there has been insufficient cooling air supply to the pump and the thermal snap switch is faulty.

Cause Circuit breaker/over-current protection tripped off.

Remedy Make sure that the circuit breaker uses the fuses Type C and over-current protection is set to appropriate value according to your wiring setup. Refer to [Table: Electrical supplies](#) for details.

Fault The pump is vibrating excessively (visibly shaking)

Cause The anti-rotation device is damaged.

Remedy If there is an audible regular pounding sound, the anti-rotation device may be damaged. Switch off the pump immediately. Remove the front cover and do the inspection of the anti-rotation device for any cracks/rupture. If you find any damage on the anti-rotation device, contact us or your supplier.

Cause The bearings are damaged.

Remedy If there is an audible clinging sound and the pump becomes too hot and has excessive vibration, bearings may be damaged. Switch off the pump immediately and contact us or your supplier.

Cause **The pump is contaminated with solid particles.**

Remedy If there is an audible clinging or rattling sound, the pump has excessive vibration, but pump temperature is normal (maximum. 65 °C on front cover), switch off the pump immediately. Remove the front cover and loose solid particles from the internal space of the pump. If this does not help, contact us or your supplier.

9. Disposal



WARNING: CONTAMINATION HAZARD

Risk of toxic exposure and acid burns. Identify, contain and safely dispose of contaminated items.

Dispose of the pump, cleaning solution, deposits removed from the pump, grease and any components safely, in accordance with all national and local safety and environmental regulations.

Pump materials suitable for recycling include cast aluminium, steel, PTFE, stainless steel, brass etc. Refer to [Materials of construction](#) on page 12 for more information.

Take care with the following:

- Fluoroelastomers which may have decomposed as the result of being subjected to high temperatures.
- Components contaminated with dangerous process substances.

10. Spares

For detailed information about the available spares, refer to parts manual A50871845.

Table 7 Spares and maintenance kits

| Spare / kit | Item Number |
|------------------------|--------------------|
| EDO - Field Service 1* | A50871720 |
| Bearing re-grease kit* | 2236232060 |

**4000 hours or 1 year whichever comes first.*

11. Accessories

Inlet/outlet connection kit

Use an inlet/outlet connection kit (NPT adapter) to allow you to fit the equipment with imperial thread.

Table 8 Inlet/outlet connection kit

| Accessory | Item Number |
|---------------------------------|--------------------|
| EDO Inlet/outlet connection kit | A50871101 |
| EDO Exhaust silencer kit | A50871100 |

12. Service

Introduction

Our products, spares and accessories are available from our companies in Belgium, Brazil, China, France, Germany, Israel, Italy, Japan, Korea, Singapore, United Kingdom, U.S.A. and a world-wide network of distributors. The majority of these centres employ Service Engineers who have undergone our comprehensive training courses.

Order spare parts and accessories from the company or distributor. When you order, please state for each part required:

- Model and Item Number of your equipment
- Serial number (if any)
- Item Number and description of the part.

Service

Our products are supported by a world-wide network of our Service Centres. Each Service Centre offers a wide range of options including: equipment decontamination, service exchange, repair, rebuild and testing to factory specifications. Equipment which has been serviced, repaired or rebuilt is returned with a full warranty.

Your local Service Centre can also provide engineers to support on-site maintenance, service or repair of your equipment.

For more information about service options, contact your nearest Service Centre or the company.

12.1 Return the equipment or components for service

Before you send your equipment to us for service or for any other reason, you must send us a completed Declaration of Contamination of Vacuum Equipment and Components – Form HS2. The HS2 form tells us if any substances found in the equipment are hazardous, which is important for the safety of our employees and all other people involved in the service of your equipment. The hazard information also lets us select the correct procedures to service your equipment.

We provide instructions for completing the form in the Declaration of Contamination of Vacuum equipment and Components – Procedure HS1.

If you are returning a vacuum pump, note the following:

- If a pump is configured to suit the application, make a record of the configuration before returning the pump. All replacement pumps will be supplied with default factory settings.
- Do not return a pump with accessories fitted. Remove all accessories and retain them for future use.
- The instruction in the returns procedure to drain all fluids does not apply to the lubricant in pump oil reservoirs.

Download the latest documents from edwardsvacuum.com/HSForms/, follow the procedure in HS1, fill in the electronic HS2 form, print it, sign it, and return the signed copy to us.



NOTICE:

If we do not receive a completed HS2 form, your equipment cannot be serviced.

CE Declaration of Conformity

We, Edwards Ltd
Innovation Drive
Burgess Hill
West Sussex
RH15 9TW
UK

Declare that the following product

| | |
|------------------------|-----------|
| EDO65 230VD/400VY 50Hz | A50871958 |
| EDO65 200VD/345VY 50Hz | A50871959 |
| EDO65 500VY 50Hz | A50871960 |

Is in conformity with the relevant requirements of European CE legislation:

2006/42/EC Machinery directive

Note: The safety objectives of the Low Voltage Directive 2014/35/EU were complied with in accordance Appendix 1 No. 1.5.1 of this directive.

2011/65/EU Restriction of certain hazardous substances (RoHS) directive
as amended by Delegated Directive (EU) 2015/863

Based on the relevant requirements of harmonised standards:

| | |
|-------------------------|--|
| EN ISO 12100:2010 | Safety of machinery. General principles for design. Risk assessment and risk reduction |
| EN 1012-2:1996 +A1:2009 | Compressors and vacuum pumps. Safety requirements. Vacuum pumps |
| EN 60034-1:2010 | Rotating electrical machines. Rating and performance |

Documentation Officer: Jana Sigmunda 300, Lutín , 78349 Czech Republic, T: +42(0) 580 582 728,
Email: documentation@edwardsvacuum.com

This declaration, based on the requirements of the listed Directives and EN ISO/IEC 17050-1, covers all product serial numbers from this date on: 2021-02-24

This declaration becomes invalid if modifications are made to the product.

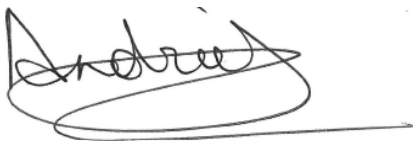

*Andries De Bock – Vice President Engineering
Industrial Vacuum Division
Cologne*



*Nina Buta – General Manager
PC Lutín*

ADDITIONAL LEGISLATION AND COMPLIANCE INFORMATION

EU RoHS Directive: Material Exemption Information

This product is compliant with the following Exemptions

Annex III:

- 6(b) **Lead** as an alloying element in aluminium containing up to 0.4% by weight

EU REACH Regulation Compliance

This product is a complex article which is not designed for intentional substance release. To the best of our knowledge the materials used comply with the requirements of REACH. The product manual provides information and instruction to ensure the safe storage, use, maintenance and disposal of the product including any substance based requirements.

Article 33.1 Declaration

This product contains Candidate List Substances of Very High Concern above 0.1%ww by article as clarified under the 2015 European Court of Justice ruling in case C-106/14.

- Lead (Pb)
This substance is present in certain aluminium components.

Additional Applicable Requirements

The product is in scope for and complies with the requirements of the following:

2012/19/EU Directive on waste electrical and electronic equipment (WEEE)

Key Component Compliance Information

| | |
|--------|---|
| Motors | 2009/125/EC Ecodesign directive requirements for energy-related products To 1 July 2021: Regulation (EC) No 640/2009 requirements for electric motors From 1 July 2021: Regulation (EU) No 2019/1781 electric motors and variable speed drives <i>Based in the requirements of harmonised standard:</i> EN 60034-30:2009: Rotating electrical machines -- Part 30: Efficiency classes of single-speed, three-phase, cage-induction motors (IE-code) |
| Fans | 2009/125/EC Ecodesign directive requirements for energy-related products Regulation (EU) No 327/2011: Industrial fans driven by motors |

材料成分声明

China Material Content Declaration

| 部件名称 Part name | 有害物质 Hazardous Substances | | | | | |
|------------------------------|------------------------------|----------------------|----------------------|--|--|--|
| | 铅 Lead (Pb) | 汞 Mercury (Hg) | 镉 Cadmium (Cd) | 六价铬 Hexavalent Chromium (Cr VI) | 多溴联苯 Polybrominated biphenyls (PBB) | 多溴二苯醚 Polybrominated diphenyl ethers (PBDE) |
| 铸铝及铝合金制品 Aluminium alloys | X | O | O | O | O | O |

O: 表示该有害物质在该部件的所有均质材料中的含量低于 GB/T 26572 标准规定的限量要求。

O: Indicates that the hazardous substance contained in all of the homogeneous materials for this part is below the limit requirement in GB/T 26572.

X: 表示该有害物质在该部件的至少一种均质材料中的含量超出 GB/T26572 标准规定的限量要求。

X: Indicates that the hazardous substance contained in at least one of the homogeneous materials used for this part is above the limit requirement of GB/T26572.

This page has been intentionally left blank.

This page has been intentionally left blank.

This page has been intentionally left blank.

