

GV SERIES DRY VACUUM PUMPS



EDWARDS THE PARTNER OF CHOICE

Edwards is a world leader in the design, technology and manufacture of vacuum pumps for industrial applications with over 100 years history.

We believe in delivering results that bring value to our customers by using our breadth of industry experience to identify and apply solutions to your problems. Using the most innovative and up-to-date modeling techniques, we can optimise the pumping configuration for customers to provide a system design giving the maximum performance in the most reliable and cost-effective way.

Get the Edwards dry advantage

Maximise your productivity and performance

Edwards has the largest installed base of dry vacuum pumps in the world. Edwards' dry claw vacuum pumps are built to the exacting standards and quality demanded by our customers. The technology is packaged into two products, the GV80 and GV110, offering many key advantages for industrial applications.



GV110



GV80

Both products offer a trouble-free and cost-effective solution to meet your needs, and offer the following advantages:



Robust

Continuous operation with the ability to handle large volumes of condensable vapours



Reliable

High tolerance of process dust and particles



Consistent output

Providing delivery of repeatable pumping performance



Low cost of ownership

With clean, quiet pumping and minimal service disruption



Environment friendly

Eliminating frequent oil changes and waste oil disposal



Industry proven, tried and tested

Specifically designed for demanding industrial applications

GV110 DRY VACUUM PUMP

The GV110 is the latest industrial dry claw vacuum pump from Edwards. Building on the advantages of the GV80, the product offers additional features and benefits including an integrated variable speed drive, modern acoustic enclosure and improved pumping performance. Like the GV80, the new product offers consistent pumping performance, minimal service intervention and low cost of ownership for a variety of industrial applications.

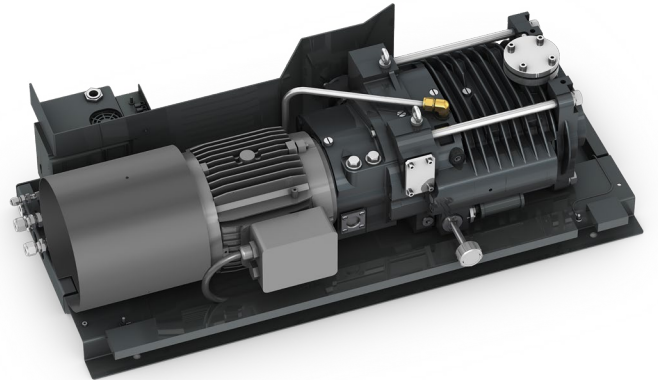

Variable Speed Drive technology to meet process demand



Consistent and repeatable performance in the most demanding of applications



Cooling water circulation optimization



Maximum uptime with minimal maintenance for reduced user intervention



Modern acoustic enclosure for a quieter operation



No contaminated waste oil for disposal or reclaim



Able to operate continuously at high-pressure levels

Drystar® GV80 and EH500 booster configured packages

Standard configured packages are available based on the GV80 offering additional features, the Drystar® GV80. These standard options are available as a pump only option or combined with the EH500 hydrokinetic drive mechanical booster offering 500m³h⁻¹ for applications where increased pumping speed and/or lower vacuum levels are required. For further details please contact your Edwards representative.



- Pre-configured pumping systems enabling ease of installation and operation
- Packages and pumping systems suitable for a wide range of applications and environments
- Packages configured for hydrocarbon or PFPE lubrication (fluid Included)

Industrial applications



- Backing pump for high vacuum applications
- Flat panel display
- Gas cylinder evacuation
- Heat treatment
- Pharmaceutical freeze drying
- Research and development
- Refrigeration and air conditioning
- System evacuation
- Drying, and backfilling
- Surface treatment
- Thin film coating technologies
- Vacuum drying and distillation
- Vacuum metallurgy processes



Technical data for GV110

		Unit	GV100
Peak pumping speed 50 Hz		m ³ /hr (cfm)	110 (64.7)
Peak pumping speed 60 Hz		m ³ /hr (cfm)	
Ultimate pressure		mbar (Torr)	6 x 10 ⁻³ (4.5 x 10 ⁻³)
Full load power	@ ultimate pressure	Kw (hp)	2.6 kW (3.5)
	@ peak pumping load	Kw (hp)	4.5 kW (4.7)
Electrical	Supply options		EU-US-CN 50/60Hz, 400V/50Hz - 460V/60Hz - 380V/50Hz ASIA 50/60Hz 200V/50Hz, 200V/60Hz, 380V/60Hz Note: See part number for specific voltage offerings.
Vacuum couplings	Inlet		ISO40
	Exhaust		NW40
Cooling			Water
Cooling water	Nominal Flow	l/min (gal/min)	5 (1.32)
	Supply pressure (MAX)	bar.a (psig)	8 (116)
	DP across pump (MIN)	bar.a (psig)	2.1 (30)
	Temperature	°C (°F)	5-35 (41-95)
	Connection	In	1/2" Quick connect coupling (mating half provided)
Purge gas (N2 or CDA)	Pressure	bar.a (psig)	0.5 (6-8)
	Light duty	sl/min	15 (typically)
	Connection	Out	1/2" Quick connect plug (mating half provided)
Dimensions	L x W x H	mm (in)	1060 x 502 x 316 (42 x 20 x 12.5)
	Footprint	m ² (ft ²)	0.532 m ² (5.73)
Weight		Kg (lbs)	210 kg (463)
Noise level with exhaust silencer		dB(A)	<75 dBA
Exhaust Back Pressure (MAX)		bar.a (psig)	1.3 (0.4)
Lubrication	Volume	l (gal)	0.4 (0.1)
	Type	Hydrocarbon	SHC 629
Pump Electrical motor rating		kW/HP	4/4.5
Typical pump rotation speed - 50/60 Hz electrical supply		rev.min-1	4100
Protection grade		IP	42
Warm-up time to pump operating temperature		min	15
Ambient operating temperature range		°C (°F)	0 to 40 (32 to 104)
Maximum ambient operating humidity		RH	80%

Performance Curves

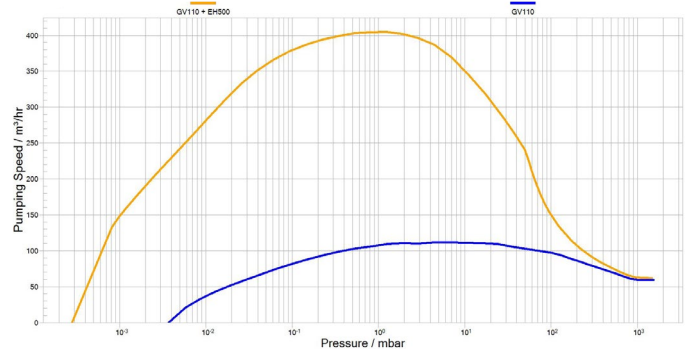
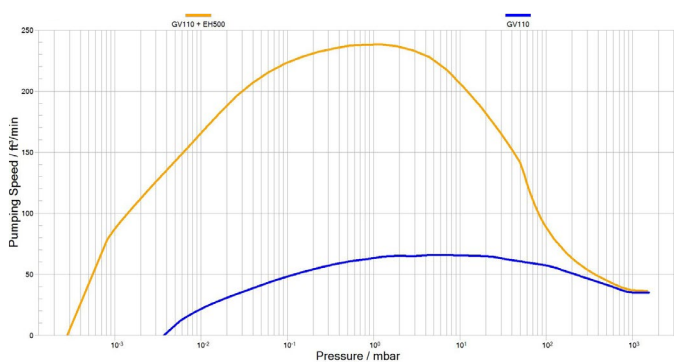

Technical data for GV80

		Unit	GV80	Drystar® GV80/EH500
Peak pumping speed 50 Hz		m ³ /hr (cfm)	80 (47)	390 (230)
Peak pumping speed 60 Hz		m ³ /hr (cfm)	94 (56)	471 (277)
Ultimate pressure		mbar (Torr)	<3 x 10 ⁻² (<2 x 10 ⁻²)	<3 x 10 ⁻² (<2 x 10 ⁻²)
Full load power	@ ultimate pressure	Kw (hp)	3.6 (4.8)	4.3 (5.6)
	@ peak pumping load	Kw (hp)	5.8 (7.8)	6.7 (9.0)
Electrical	Supply options		EU-US-CN 50/60Hz, 400V/50Hz - 460V/60Hz - 380V/50Hz ASIA 50/60Hz 200V/50Hz, 200V/60Hz, 380V/60Hz Note: See part number for specific voltage offerings.	
Vacuum couplings	Inlet		ISO40	ISO100
	Exhaust			NW40
Cooling			Water	Water/Air
Cooling water	Flow	l/min (gal/min)	8 (2.1)	8 (2.1)
	Supply pressure (MAX)	bar.a (psig)		8 (116)
	DP across pump (MIN)	bar.a (psig)		2.1 (30)
	Temperature	°C (°F)		5-35 (41-95)
	Connection	In		1/2" Quick connect coupling (mating half provided)
	Out		1/2" Quick connect plug (mating half provided)	
Purge gas (N2 or CDA)	Pressure	bar.a (psig)		0.5 (6-8)
	Light duty	sl/min		15 (typically)
	Connection		1/4" Quick connect coupling (mating half provided)	
Dimensions	L x W x H	mm (in)	860 x 607 x 344 (33.8 x 23.9 x 13.5)	932 x 607 x 624 (36.7 x 23.9 x 24.6)
	Footprint	m ² (ft ²)		0.43 (4.63)
Weight		Kg (lbs)	165 (364)	240 (529)
Noise level with exhaust silencer		dB(A)		<78
Exhaust Back Pressure (MAX)		bar.a (psig)		1.3 (0.4)
Lubrication	Volume	l (gal)	0.4 (0.1)	1.4 (0.4)
	Type		Hydrocarbon PFPE	SHC 629/ULtragrade 20 YVAC 25/6 / YVAC 16/6
Pump Electrical motor rating		kW/HP	4/4.5	
Typical pump rotation speed - 50Hz electrical supply		rev.min-1	3000	
Typical pump rotation speed - 60Hz electrical supply		rev.min-1	3600	
Protection grade		IP	55	
Warm-up time to pump operating temperature		min	15	
Ambient operating temperature range		°C (°F)	0 to 40 (32 to 104)	
Maximum ambient operating humidity		RH	100%	

Performance Curves

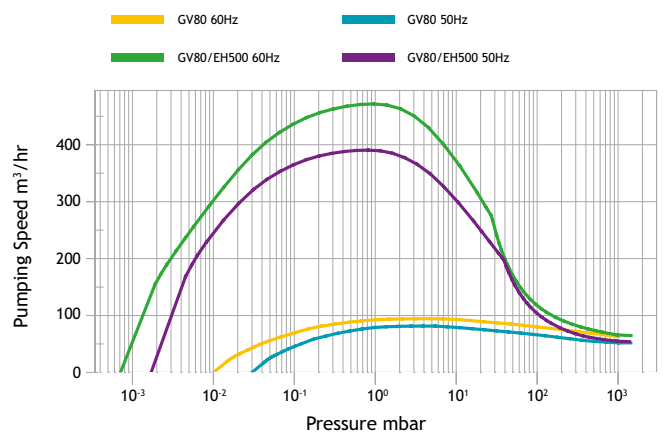
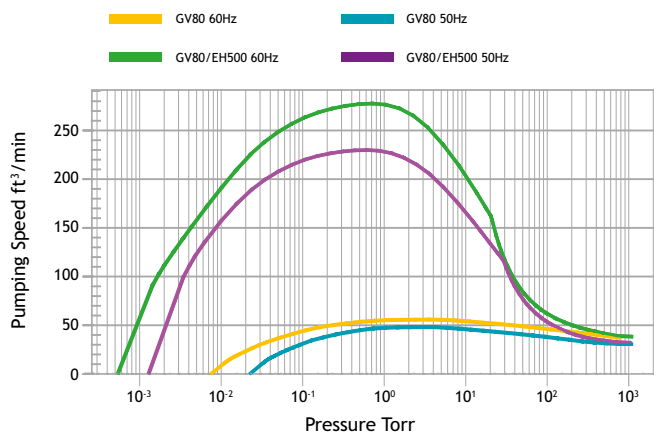

Drawings and dimensions

GV110

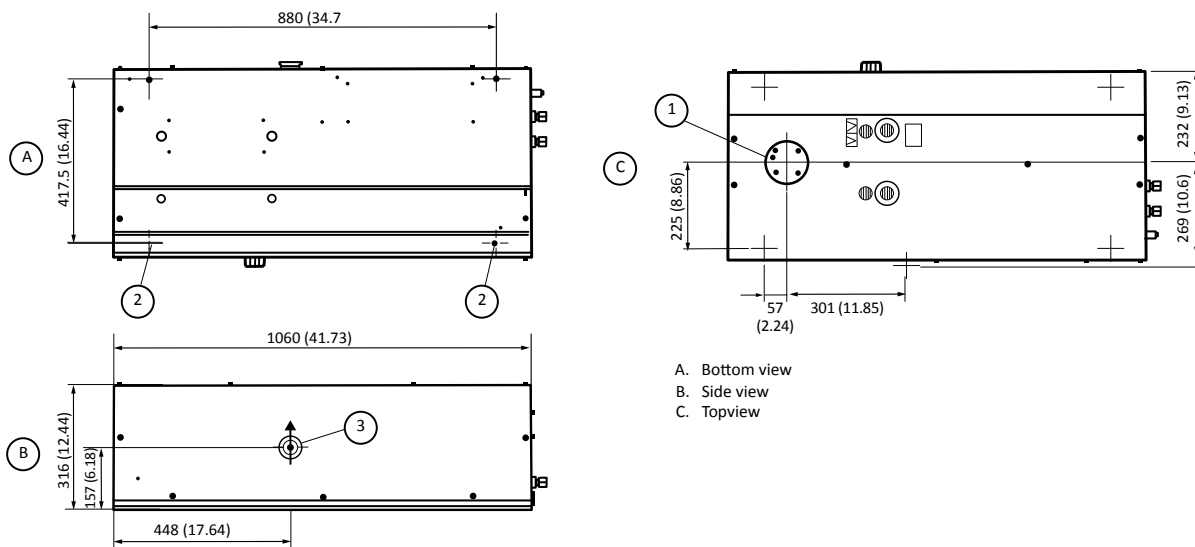

A. Bottom view
B. Side view
C. Topview

GV80

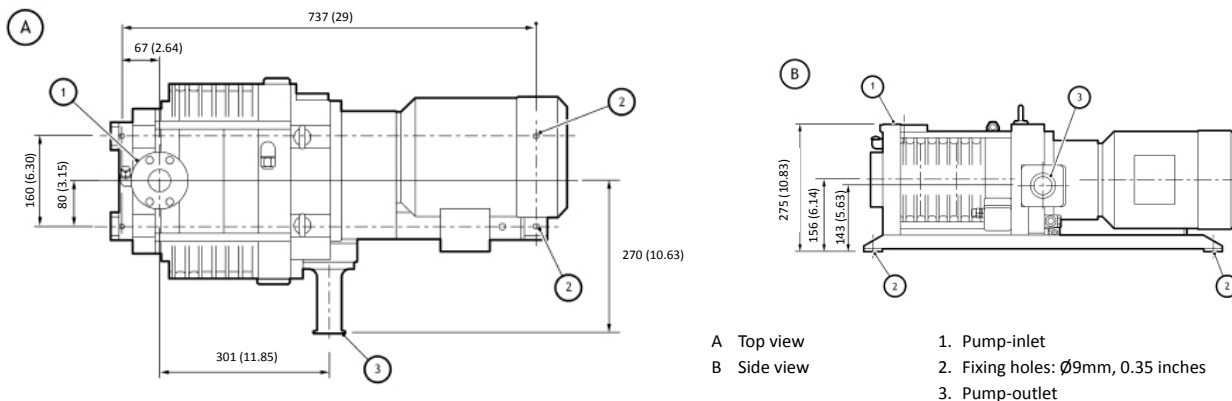

A Top view
B Side view

1. Pump-inlet
2. Fixing holes: $\varnothing 9$ mm, 0.35 inches
3. Pump-outlet

Drystar® GV80 & EH500 combination

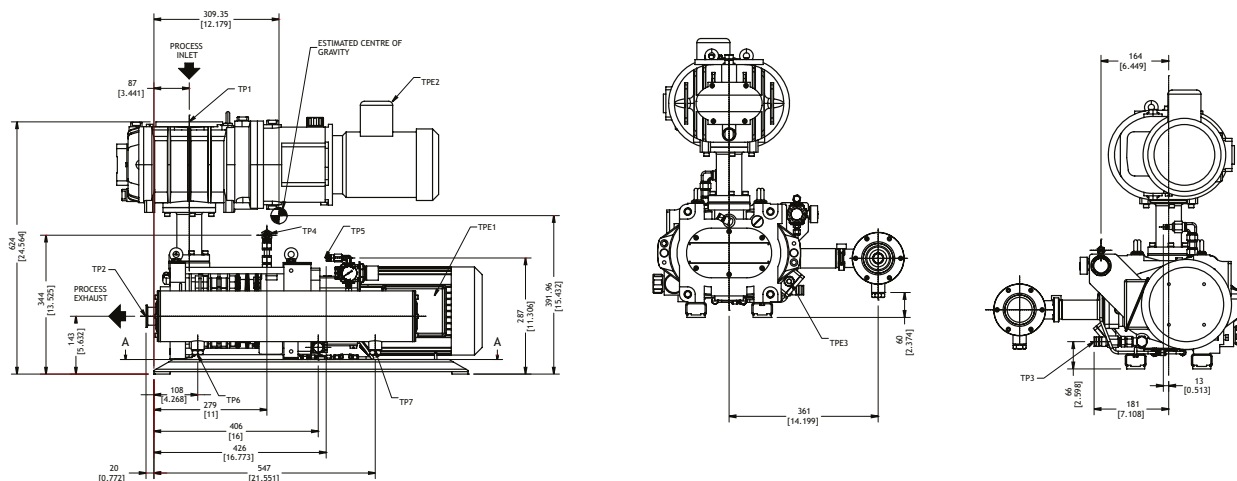

Ordering information

GV110

Part Number	Description	Voltage
A70227900	GV110 HV Dry Vacuum Pump	400 V 50 Hz
A70227940	GV110 LV Dry Vacuum Pump	200 V 50 Hz

Existing GV80 accessories are compatible with the GV110:

Part Number	Description
A50559000	GV80-EH250 Booster Connection Kit
A50560000	GV80-EH500A Booster Connection Kit
NCD089000	GV80/160 Exhaust Silencer

GV80

Part Number	Description	Voltage
A70216940	GV80 IE3	EU/US/CN 50/60HZ
A70217940	GV80 FX IE3	EU/US/CN 50/60HZ
NR8030000	GV80	EU/US/CN 50/60HZ
NR8035000	GV80F	EU/US/CN 50/60HZ
NRA523000	GV80 EURO + TCV KIT + SILENCER	EU/US/CN 50/60HZ
A70217934	GV80 FX IE3 (with gearbox purge)	ASIA 50/60HZ
NR2VZ100	GV80 PUMP PACKED	EU/US/CN 50/60HZ
A70216934	GV80 IE3	ASIA 50/60 Hz



Service and support



To ensure your GV110 and GV80 pump and system maintains optimal performance and reliability, we offer a wide range of service solutions, tailored to meet your needs. From Field Service intervention to Managed Maintenance agreements, we will take care of your pump to ensure that it continues to deliver clean, consistent, efficient performance, with lower running cost and optimum total cost of ownership for its entire operating life.

Selecting original spare parts, maintenance kits and oil, means that every critical part performs as it was intended. Form, fit and function are guaranteed. Our service engineers only fit 100% genuine parts to ensure you receive the best result from each and every service.

- **Service at your convenience.** Our highly trained Service Technicians carry out commissioning, vacuum health check, routine maintenance, troubleshooting and repair for many types of vacuum equipment. We invest in the tools, training and inventory to enable service in a timely, safe and consistent manner, utilising our best known methods.
- **Managed Maintenance agreements.** Regular scheduled maintenance can identify potential problems before they occur and plans can be structured around different levels of care. It enables cost management and will help you to avoid the risk and expense associated with unplanned downtime. Managed Maintenance lets you focus on your business, we will take care of your maintenance.
- **Service and re-manufacturing** in one of our Service Technology Centres. No matter the condition of your pump our vacuum specialists can handle it. We are experts in vacuum pump maintenance and support pumps from virtually every type of application.



GLOBAL CONTACTS

Publication Number: 3602 111 9 01
 © Edwards Limited 2019. All rights reserved
 Edwards and the Edwards logo are trademarks of
 Edwards Limited.

Whilst we make every effort to ensure that we
 accurately describe our products and services,
 we give no guarantee as to the accuracy or
 completeness of any information provided in
 this brochure.

Edwards Ltd, registered in England and Wales
 No. 6124750, registered office: Innovation Drive,
 Burgess Hill, West Sussex, RH15 9TW, UK.

EMEA

UK	+44 1444 253 000 (local rate) 08459 212223
Belgium	+32 2 300 0730
France	+33 1 4121 1256
Germany	0800 000 1456
Italy	+ 39 02 48 4471
Israel	+ 972 8 681 0633

ASIA PACIFIC

China	+86 400 111 9618
India	+91 20 4075 2222
Japan	+81 47 458 8836
Korea	+82 31 716 7070
Singapore	+65 6546 8408
Taiwan	+886 3758 1000

AMERICAS

USA	+1 800 848 9800
Brazil	+55 11 3952 5000